

UNCLASSIFIED
S1000DGUN-91005-MM301-00

Operator & Field Maintenance Manual

FOR

Phun Gun 30D (NSN 4940-00-017-0000) (EIC OOH)

DISTRIBUTION STATEMENT A: Approved for public release; distribution is unlimited.

WARNING: Export control statement here.

DESTRUCTION NOTICE: Destroy by any means possible to prevent disclosure of contents or reconstruction of the document.

General purpose notices may appear here.

HEADQUARTERS, DEPARTMENT OF THE ARMY

15 SEPTEMBER 2011

UNCLASSIFIED

Phun Gun - Safety summary

References

Table 1 References

CHAP NO./DOCUMENT NO.	TITLE
None	

1 WARNING SUMMARY

This warning summary contains general safety warnings and hazardous materials warnings that must be understood and applied during operation and maintenance of this equipment. Failure to observe these precautions could result in injury or death. Also included are explanations of safety and hazardous materials icons used within the technical manual.

2 FIRST AID

FOR INFORMATION ON FIRST AID, REFER TO FM 4-25.11 FIRST AID.

3 EXPLANATION OF STANDARD SAFETY WARNING ICONS



EYE PROTECTION

Person with goggles shows that the material will injure the eyes.



FLYING PARTICLES

Arrows bouncing off face show that particles flying through the air will harm face.

4 GENERAL WARNING INFORMATION

WARNING



Wear safety glasses/goggles to prevent potential eye injury.

Wear safety glasses when removing and installing spring-loaded components. Failure to do so could cause serious eye injury.

WARNING

Do not aim launcher at eyes or face.

Do not modify components, use repair parts, or interchange components other than those authorized by this Technical Manual. This includes other models of phun guns.

Unload the air blaster when not in use.

DATA MODULE CODE / DM TITLE	PAGE COUNT	SEQ. NO.	ISSU E NO.
Phun Gun - Procedures to activate ammunition [S1000DGUN-0-00-00-00-00A-120G-A]	3 pages	0015 / 0020	001
Phun Gun - Normal operation procedures [S1000DGUN-0-00-00-00-00A-131A-A]	5 pages	0010	001
Phun Gun - Unusual environment/weather [S1000DGUN-0-00-00-00-00A-142B-A]	3 pages	0011	001
Phun Gun - PMCS [S1000DGUN-0-00-00-00-00A-200B-A]	1 page	0017	001
Phun Gun - Other procedures to clean [S1000DGUN-0-00-00-00-00A-258A-A]	2 pages	0022	001
Phun Gun - Test and inspection [S1000DGUN-0-00-00-00-00A-300B-A]	2 pages	0018 / 0040	001
Phun Gun - Ammunition unloading [S1000DGUN-0-00-00-00-00A-525A-A]	2 pages	0021 / 0039	001
Phun Gun - Assembly of equipment [S1000DGUN-0-00-00-00-00A-710C-A]	3 pages	0014	001
Phun Gun - Ammunition loading [S1000DGUN-0-00-00-00-00A-725A-A]	4 pages	0019 / 0038	001
Phun Gun - Preparation for storage or shipment [S1000DGUN-0-00-00-00-00A-810C-A]	2 pages	0041	001
Phun Gun - Unpacking [S1000DGUN-0-00-00-00-00A-840B-A]	2 pages	0012	001
Phun Gun - Checking unpacked equipment [S1000DGUN-0-00-00-00-00A-870B-A]	2 pages	0013	001
Phun Gun - MAC [S1000DGUN-0-00-00-00-00A-916A-A]	2 pages	0045	001
Receiver Assembly - Inspect [S1000DGUN-0-00-AA-00-00A-280A-A]	2 pages	0023	001
Barrel Assembly - Inspect [S1000DGUN-0-00-AB-00-00A-280A-A]	2 pages	0024	001
Trigger Assembly - Adjust [S1000DGUN-0-00-AC-00-00A-271A-A]	2 pages	0025	001
Belt Assembly - Adjust [S1000DGUN-0-00-AD-00-00A-271A-A]	2 pages	0027	001
Belt Assembly - Inspect [S1000DGUN-0-00-AD-00-00A-280A-A]	2 pages	0028	001
Belt Assembly - Assembly procedure [S1000DGUN-0-00-AD-00-00A-710A-A]	4 pages	0026	001
Slide Assembly - Align [S1000DGUN-0-00-AE-00-00A-272A-A]	2 pages	0030	001
Slide Assembly - Inspect [S1000DGUN-0-00-AE-00-00A-280A-A]	2 pages	0029	001
Slide Assembly - Removal procedure [S1000DGUN-0-00-AE-00-00A-520A-A]	3 pages	0031	001
Slide Assembly - Repair [S1000DGUN-0-00-AE-00-00A-685A-A]	2 pages	0032	001
Slide Assembly - Replace [S1000DGUN-0-00-AE-00-00A-685C-A]	3 pages	0033	001
Safety Plate - Adjust [S1000DGUN-0-00-AG-00-00A-271A-A]	2 pages	0035	001
Safety Plate - Align [S1000DGUN-0-00-AG-00-00A-272A-A]	3 pages	0034	001
Safety Plate - Replace [S1000DGUN-0-00-AG-00-00A-685C-A]	3 pages	0036	001
Safety Plate Release Button - Adjust [S1000DGUN-0-00-AH-00-00A-271A-A]	3 pages	0037	001

Phun Gun - Title page

References

Table 1 References

CHAP NO./DOCUMENT NO.	TITLE
None	

REPORTING ERRORS AND RECOMMENDING IMPROVEMENTS

You can help improve this manual. If you find any mistakes or if you know of a way to improve the procedures, please let us know. Mail your letter or DA Form 2028 (Recommended Changes to Publications and Blank Forms), located in the back of this manual directly to: USAMC Logistics Support Activity, ATTN: AMXLS-AP, Redstone Arsenal, AL 35898-7466. You may also send your recommended changes via electronic mail or by fax. Our fax number is [NEED DSN AND FAX NUMBER]. Our e-mail address is logsa.tmss@conus.army.mil. A reply will be furnished to you.

TABLE OF CONTENTS

	DM SEQUENCE NO.
Phun Gun - How to use this manual [S1000DGUN-0-00-00-00-00A-018B-A]	0004
CHAPTER 1 GENERAL INFORMATION, EQUIPMENT DESCRIPTION AND THEORY OF OPERATION	
General Information	
Phun Gun - General data [S1000DGUN-0-00-00-00-00A-010A-A]	0005
Phun Gun - General information [S1000DGUN-0-00-00-00-00A-010B-A]	0006
Equipment Description and Data	
Phun Gun - Equipment description and data [S1000DGUN-0-00-00-00-00A-000B-A]	0007
Theory of Operation	
Phun Gun - Theory of Operation [S1000DGUN-0-00-00-00-00A-042F-A]	0008
CHAPTER 2 OPERATOR INSTRUCTIONS	
Description and Use of Operator Controls and Indicators	
Phun Gun - Description and use of controls and indicators [S1000DGUN-0-00-00-00-00A-111A-A]	0009
Operation Under Usual Conditions	
Phun Gun - Normal operation procedures [S1000DGUN-0-00-00-00-00A-131A-A]	0010
Operation Under Unusual Conditions	
Phun Gun - Unusual environment/weather [S1000DGUN-0-00-00-00-00A-142B-A]	0011
CHAPTER 3 FIELD MAINTENANCE INSTRUCTIONS	
Service Upon Receipt	
Service Upon Receipt of Materiel	
Phun Gun - Unpacking [S1000DGUN-0-00-00-00-00A-840B-A]	0012
Phun Gun - Checking unpacked equipment [S1000DGUN-0-00-00-00-00A-870B-A]	0013
Installation Instructions	
Phun Gun - Assembly of equipment [S1000DGUN-0-00-00-00-00A-710C-A]	0014
Phun Gun - Procedures to activate ammunition [S1000DGUN-0-00-00-00-00A-120G-A]	0015
Preventive Maintenance Checks and Services - Field	
Phun Gun - PMCS introduction [S1000DGUN-0-00-00-00-00A-018F-A]	0016
Phun Gun - PMCS [S1000DGUN-0-00-00-00-00A-200B-A]	0017

TABLE OF CONTENTS

DM SEQUENCE NO.

Maintenance

Phun Gun Maintenance

Phun Gun - Test and inspection [S1000DGUN-0-00-00-00-00A-300B-A]	0018
Phun Gun - Ammunition loading [S1000DGUN-0-00-00-00-00A-725A-A]	0019
Phun Gun - Procedures to activate ammunition [S1000DGUN-0-00-00-00-00A-120G-A]	0020
Phun Gun - Ammunition unloading [S1000DGUN-0-00-00-00-00A-525A-A]	0021
Phun Gun - Other procedures to clean [S1000DGUN-0-00-00-00-00A-258A-A]	0022

Receiver Maintenance

Receiver Assembly - Inspect [S1000DGUN-0-00-AA-00-00A-280A-A]	0023
---	------

Barrel Maintenance

Barrel Assembly - Inspect [S1000DGUN-0-00-AB-00-00A-280A-A]	0024
---	------

Trigger Maintenance

Trigger Assembly - Adjust [S1000DGUN-0-00-AC-00-00A-271A-A]	0025
---	------

Belt Maintenance

Belt Assembly - Assembly procedure [S1000DGUN-0-00-AD-00-00A-710A-A]	0026
Belt Assembly - Adjust [S1000DGUN-0-00-AD-00-00A-271A-A]	0027
Belt Assembly - Inspect [S1000DGUN-0-00-AD-00-00A-280A-A]	0028

Slide Maintenance

Slide Assembly - Inspect [S1000DGUN-0-00-AE-00-00A-280A-A]	0029
Slide Assembly - Align [S1000DGUN-0-00-AE-00-00A-272A-A]	0030
Slide Assembly - Removal procedure [S1000DGUN-0-00-AE-00-00A-520A-A]	0031
Slide Assembly - Repair [S1000DGUN-0-00-AE-00-00A-685A-A]	0032
Slide Assembly - Replace [S1000DGUN-0-00-AE-00-00A-685C-A]	0033

Safety Plate Maintenance

Safety Plate - Align [S1000DGUN-0-00-AG-00-00A-272A-A]	0034
Safety Plate - Adjust [S1000DGUN-0-00-AG-00-00A-271A-A]	0035
Safety Plate - Replace [S1000DGUN-0-00-AG-00-00A-685C-A]	0036

Safety Plate Release Button Maintenance

Safety Plate Release Button - Adjust [S1000DGUN-0-00-AH-00-00A-271A-A]	0037
--	------

Ammunition Care and Usage

Phun Gun - Ammunition loading [S1000DGUN-0-00-00-00-00A-725A-A]	0038
---	------

TABLE OF CONTENTS

	DM SEQUENCE NO.
Phun Gun - Ammunition unloading [S1000DGUN-0-00-00-00-00A-525A-A]	0039
CHAPTER 4 TEST AND INSPECTION MAINTENANCE INSTRUCTIONS	
Phun Gun - Test and inspection [S1000DGUN-0-00-00-00-00A-300B-A]	0040
CHAPTER 5 SHIPMENT/MOVEMENT AND STORAGE MAINTENANCE INSTRUCTIONS	
Phun Gun - Preparation for storage or shipment [S1000DGUN-0-00-00-00-00A-810C-A]	0041
CHAPTER 6 AMMUNITION MARKING MAINTENANCE INSTRUCTIONS	
Phun Gun - Ammunition marking [S1000DGUN-0-00-00-00-00A-067C-A]	0042
CHAPTER 7 SUPPORTING INFORMATION	
Phun Gun - References [S1000DGUN-0-00-00-00-00A-017B-A]	0043
Phun Gun - MAC introduction [S1000DGUN-0-00-00-00-00A-018D-A]	0044
Phun Gun - MAC [S1000DGUN-0-00-00-00-00A-916A-A]	0045
Phun Gun - Components of End Item (COEI) list [S1000DGUN-0-00-00-00-00A-105D-A]	0046
Phun Gun - Basic Issue Items (BI) list [S1000DGUN-0-00-00-00-00A-105C-A]	0047
Phun Gun - Additional Authorization List (AAL) [S1000DGUN-0-00-00-00-00A-104C-A]	0048
Phun Gun - Expendable and durable items list [S1000DGUN-0-00-00-00-00A-070D-A]	0049
Phun Gun - Reporting errors and recommending improvements [S1000DGUN-0-00-00-00-00A-023B-A] . . .	0050
Phun Gun - Authentication page [S1000DGUN-0-00-00-00-00A-023C-A]	0051

Phun Gun - How to use this manual

References

Table 1 References

CHAP NO./DOCUMENT NO.	TITLE
None	

1 INTRODUCTION

The safest, easiest, and best way to operate and maintain the Phun Gun is to use this manual. Learning to use the TM is as easy as reading through the next few pages of this section. Knowing what is in this manual and how to use it will save you time and work and will help you avoid exposing yourself to unnecessary hazards while performing your job.

This manual is written in data module format. Each chapter is divided into data modules, which are identified by a 17-41-character code located on the lower right-hand corner of each page.

Chapters divide the manual into major categories of information (e.g., General Information, Equipment Description and Theory of Operation, Operator Instructions, Maintenance Instructions, and Supporting Information).

Scan through this manual to become familiar with its organization and contents before attempting to operate or maintain the Phun Gun.

1.1 General Information

References are to data modules in this manual or to other publications.

Each task begins with a setup sheet (preliminary requirements). It tells you what you need to do the task: tools, materials, personnel, parts, and other publications. It tells you what must be done to the equipment before you begin the task (required conditions) and provides general safety instructions. If applicable, it tells you what must be done to the equipment after you complete the task (closing requirements).

2 CONTENTS OF THIS MANUAL

2.1 Front Matter

- 1 A Phun Gun - Safety summary [S1000DGUN-0-00-00-00-00A-012J-A] is located at the beginning of this manual. Become familiar with these warnings before operating or performing maintenance on the equipment.
- 2 A Table of Contents, located in the front of the manual, lists all chapters and data modules in the publication. It also provides Reporting Errors and Recommending Improvements information and DA Form 2028 addresses, for the submittal of corrections to this manual.

2.2 Chapters

- 1 Chapter 1 provides General Information on the manual and the equipment. This information is contained within the following data modules:

-
- 1.1 Phun Gun - General data [S1000DGUN-0-00-00-00-00A-010A-A]
 - 1.2 Phun Gun - General information [S1000DGUN-0-00-00-00-00A-010B-A]
 - 1.3 Phun Gun - Equipment description and data [S1000DGUN-0-00-00-00-00A-000B-A]
 - 2 Chapter 2 covers Operator Instructions. This includes:
 - 2.1 Phun Gun - Description and use of controls and indicators [S1000DGUN-0-00-00-00-00A-111A-A]
 - 2.2 OPERATION UNDER USUAL CONDITIONS, including: Phun Gun - Normal operation procedures [S1000DGUN-0-00-00-00-00A-131A-A]
 - 2.3 OPERATION UNDER UNUSUAL CONDITIONS, including: Phun Gun - Unusual environment/weather [S1000DGUN-0-00-00-00-00A-142B-A]
 - 3 Chapter 3 covers Operator and Field Maintenance Procedures. Major areas covered are all Preventive Maintenance Checks and Services (PMCS), Service Upon Receipt, and all maintenance procedures authorized by the Maintenance Allocation Chart (MAC) for this manual, organized in Functional Group Code (FGC) sequence.
 - 4 Chapter 4 covers Test and Inspection Maintenance Instructions.
 - 5 Chapter 5 covers Shipment/Movement and Storage Maintenance Instructions.
 - 6 Chapter 6 covers Ammunition Marking Maintenance Instructions.
 - 7 Chapter 7 covers Supporting Information. Major areas covered are:
 - 7.1 Phun Gun - References [S1000DGUN-0-00-00-00-00A-017B-A]
 - 7.2 Phun Gun - MAC introduction [S1000DGUN-0-00-00-00-00A-018D-A]
 - 7.3 Phun Gun - MAC [S1000DGUN-0-00-00-00-00A-916A-A]
 - 7.4 Phun Gun - Components of End Item (COEI) list [S1000DGUN-0-00-00-00-00A-105D-A]
 - 7.5 Phun Gun - Basic Issue Items (BII) list [S1000DGUN-0-00-00-00-00A-105C-A]
 - 7.6 Phun Gun - Additional Authorization List (AAL) [S1000DGUN-0-00-00-00-00A-104C-A]
 - 7.7 Phun Gun - Expendable and durable items list [S1000DGUN-0-00-00-00-00A-070D-A]

2.3 Rear Matter

- 1 Phun Gun - Authentication page [S1000DGUN-0-00-00-00-00A-023C-A]
- 2 Phun Gun - Reporting errors and recommending improvements [S1000DGUN-0-00-00-00-00A-023B-A]

3 FEATURES OF THIS MANUAL

WARNINGS, CAUTIONS, NOTES, subject headings, and other important information are highlighted in BOLD print as a visual aid.

Statements and words of particular interest may be printed in CAPITAL LETTERS to create emphasis.

Technical instructions may include metric units as well as standard units.

NOTE

If at any time you are unsure how to use this manual or you cannot locate the information you need, notify your supervisor.

CHAPTER 1

**GENERAL INFORMATION, EQUIPMENT DESCRIPTION AND THEORY OF
OPERATION**

Phun Gun - General data

References

Table 1 References

CHAP NO./DOCUMENT NO.	TITLE
None	

1 SCOPE

This manual includes information for Operator and Field Maintenance. It applies solely to the Phun Gun 30D.

2 DESTRUCTION OF ARMY MATERIEL TO PREVENT ENEMY USE

Procedures and materials used for the destruction of the Phun Gun to prevent enemy use are found in TM 750-244-7 Procedures for destruction of equipment in federal supply classifications 1000, 1005, 1010, 1015, 1020, 1025, 1030, 1055, 1090 and 1095 to prevent enemy use.

3 PREPARATION FOR STORAGE OR SHIPMENT

Refer to Phun Gun - Preparation for storage or shipment [S1000DGUN-0-00-00-00-00A-810C-A].

4 LIST OF ABBREVIATIONS/ACRONYMS

AOAP	Army Oil Analysis Program
BII	Basic Issue Items
CPC	Corrosion Prevention and Control
COEI	Components of End Item
DA	Department of the Army
EIR	Equipment Improvement Recommendations
IAW	In Accordance With
MAC	Maintenance Allocation Chart
NSN	National Stock Number
PMCS	Preventive Maintenance Checks and Services
TM	Technical Manual
UOC	Usable On Code

Phun Gun - General information

References

Table 1 References

CHAP NO./DOCUMENT NO.	TITLE
None	

1 **MAINTENANCE FORMS, RECORDS, AND REPORTS**

Department of the Army forms and procedures used for equipment maintenance are prescribed in DA PAM 750-8 The Army Maintenance Management System (TAMMS) Users Manual.

2 **REPORTING EQUIPMENT IMPROVEMENT RECOMMENDATIONS (EIR)**

If your Phun Gun needs improvement, let us know. Send us an EIR. You, the user, are the only one who can tell us what you do not like about the design. Put it on an SF 368 Product Quality Deficiency Report. Mail to: USAMC Logistics Support Activity, ATTN: AMXLS-AP, Redstone Arsenal, AL 35898-7466. We will send you a reply.

3 **CORROSION PREVENTION AND CONTROL (CPC)**

CPC of materiel is a continuing concern. It is important any corrosion problems with this item be reported so that the problem can be corrected and improvements can be made to prevent the problem in the future.

While corrosion is typically associated with rusting of metals, it can also include deterioration of other materials such as rubber or plastic. Unusual cracking, softening, swelling, or breaking of these materials may be a corrosion problem.

If a corrosion problem is identified, it can be reported using SF 368 Product Quality Deficiency Report. Use of key words such as "corrosion," "rust," "deteriorization," or "cracking" will assure that the information is identified as a CPC problem.

The SF 368 Product Quality Deficiency Report should be submitted to: USAMC Logistics Support Activity, ATTN: AMXLS-AP, Redstone Arsenal, AL 35898-7466.

Phun Gun - Equipment description and data

References

Table 1 References

CHAP NO./DOCUMENT NO.	TITLE
None	

1 EQUIPMENT CHARACTERISTICS, CAPABILITIES, AND FEATURES

Phun Gun features:

- Belt fed dart blasting
- Includes 30 soft darts and 30 shells
- Rapid fire pump action
- Dart belt come apart and snaps back together to desired length

2 EQUIPMENT DATA

Shipping Weight	3.2 lbs
Length	23 inches
Range	30 feet
Magazine capacity	30 darts
Total capacity (with dart in chamber)	31 darts
Type of action	Pump
Operation	Manual

The Phun Gun has a specific length which could be included by using the <quantity> element. For example, the Phun Gun is 23 IN, which is also the same as just typing, "23 inches in length."

By including the element <quantityTolerance>, we can provide some leeway in the measurement. For example, my eyesight is bad and I cannot read the tape measure, so the Phun gun is now 23 IN ± 2 IN, which is also the same as just typing, "23 inches ± 2 inches in length."

3 LOCATION AND DESCRIPTION OF MAJOR COMPONENTS

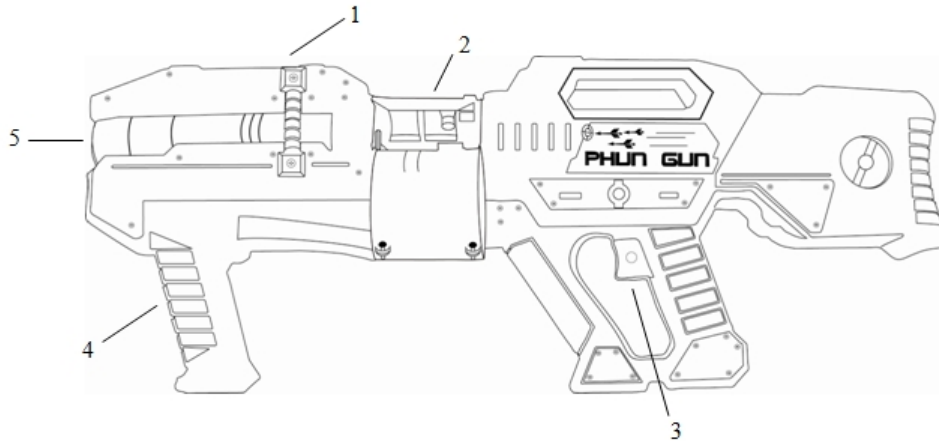

Legend to Fig 1:

1	Safety plate release button, which opens the safety plate
2	Safety plate, which provides access to the belt assembly
3	Trigger, which provides the firing function of the gun
Not pictured	Dart belt, which houses the shells
4	Slide assembly, which feeds rounds into the chamber
5	Barrel, which provides a path for projectiles

ICN-07GB6-CI001-001-01

Figure 1. Phun Gun - Major components.

Major components and descriptions of the Phun Gun are:

- Barrel, which provides a path for projectiles
- Safety plate release button, which opens the safety plate
- Safety plate, which provides access to the belt assembly
- Trigger, which provides the firing function of the gun
- Dart belt, which houses the shells
- Slide assembly, which feeds rounds into the chamber

Refer to Figure 1.

Phun Gun - Theory of Operation

References

Table 1 References

CHAP NO./DOCUMENT NO.	TITLE
None	

1 THEORY OF OPERATION

Pulling the trigger, sliding the slide assembly to the rear to open the action, and sliding the slide assembly forward again to close the action complete the entire operation of the gun. The slide assembly is mounted on gun and fully controlled by the operator. With the belt assembly fully loaded and one shell in the barrel chamber, the gun is ready to fire.

CHAPTER 2
OPERATOR INSTRUCTIONS

Phun Gun - Controls and indicators

References

Table 1 References

CHAP NO./DOCUMENT NO.	TITLE
None	

1 GENERAL

Before operating the Phun Gun 30D, read and become familiar with the location and function of all operator controls and indicators, as described herein.

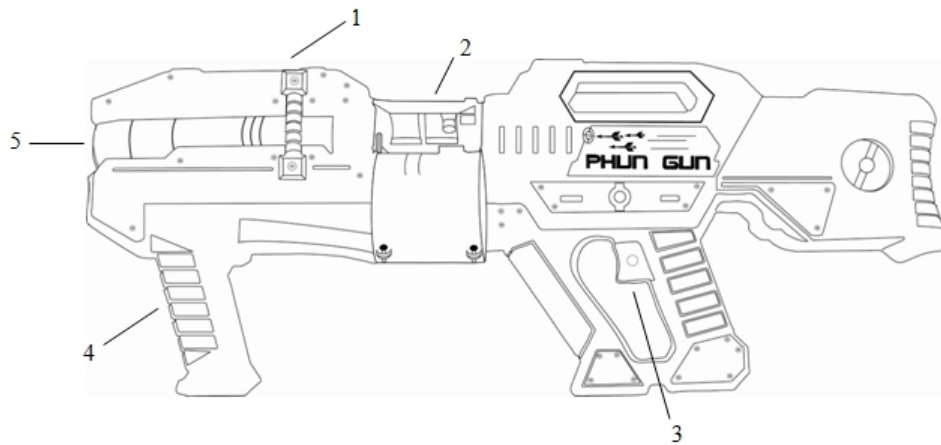

ICN-07GB6-CI001-001-01

Figure 1. Phun Gun 30D Controls and Indicators.

Table 2 Controls and indicators

KEY	CONTROL OR INDICATOR	FUNCTION
1	Safety plate release button	Push the cover release button to open the safety plate
2	Safety plate	Safety plate should remain closed when in use Safety plate should be open when loading or unloading weapon
3	Trigger	Pull trigger to launch a dart
4	Slide Assembly	Pull and push the slide assembly to load power
5	Barrel	Barrel should not be blocked in any way

Phun Gun - Normal operation procedures

References

Table 1 References

CHAP NO./DOCUMENT NO.	TITLE
None	

Preliminary requirements

Required conditions

Table 2 Required conditions

ACTION/CONDITION	DATA MODULE/TECHNICAL PUBLICATION
None	

Support equipment

Table 3 Support equipment

NAME	CAGE/REFERENCE	QUANTITY	REMARK
None			

Consumables, materials, and expendables

Table 4 Consumables, materials, and expendables

NAME	CAGE/REFERENCE	QUANTITY	REMARK
None			

Spares

Table 5 Spares

NAME	CAGE/REFERENCE	QUANTITY	REMARK
None			

Safety conditions

WARNING

Do not point launcher at people or animals.

WARNING

Do not put any objects other than the darts provided in the launcher.

WARNING

Do not attempt to modify the darts or launcher in any way.

WARNING

Do not aim at eyes or face.

WARNING

Unload the air blaster when not in use.

Procedure

- 1 Push the safety plate release button to open the safety plate.



ICN-07GB6-GUNLOAD1-001-01

Figure 1. Safety plate, open.

- 2 Look into chamber to make sure there is no round chambered.
- 3 Place the fully assembled belt assembly into the phun gun as shown. Refer to Phun Gun - Assembly of equipment [S1000DGUN-0-00-00-00-00A-710C-A] for more information.

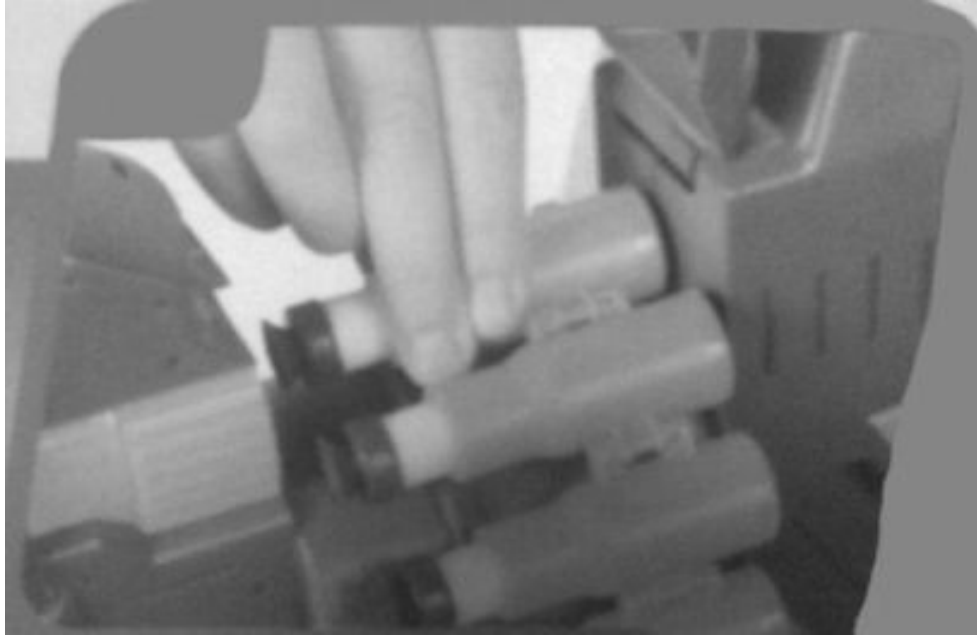

ICN-07GB6-GUNLOAD2-001-01

Figure 2. Dart belt.

- 4 Close the safety plate.

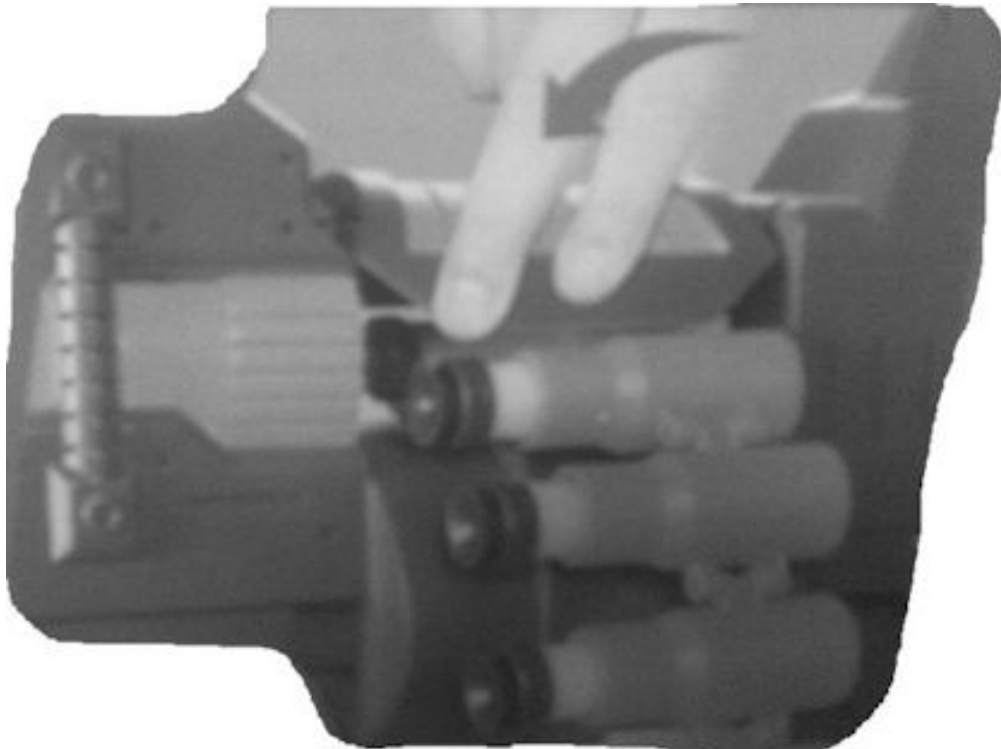

ICN-07GB6-GUNLOAD3-001-01

Figure 3. Safety plate, close.

- 5 Pull and push the slide assembly to load power.

Applicable to: All

S1000DGUN-0-00-00-00-00A-131A-A



ICN-07GB6-GUNLOAD4-001-01

Figure 4. Load power.

WARNING

The weapon is now combat ready (in other words, the ammunition is now loaded).

- 6 Pull trigger to launch dart.



ICN-07GB6-GUNLOAD5-001-01

Figure 5. Launch dart.

- 7 Pull and push slide assembly again to automatically load another shell into place.



ICN-07GB6-GUNLOAD6-001-01

Figure 6. Load another shell.

Requirements after job completion

Required conditions

Table 6 Required conditions

ACTION/CONDITION	DATA MODULE/TECHNICAL PUBLICATION
None	

Phun Gun - Unusual environment/weather

References

Table 1 References

CHAP NO./DOCUMENT NO.	TITLE
None	

General information

Instructions

Refer to Phun Gun - PMCS [S1000DGUN-0-00-00-00-00A-200B-A] for preventive maintenance checks and services to be made when the materiel is subjected to unusual conditions.

Report any chronic failure of materiel resulting from subjection to extreme conditions in accordance with TM 38-750 Army Equipment Records Procedure.

Preliminary requirements

Required conditions

Table 2 Required conditions

ACTION/CONDITION	DATA MODULE/TECHNICAL PUBLICATION
None	

Support equipment

Table 3 Support equipment

NAME	CAGE/REFERENCE	QUANTITY	REMARK
None			

Consumables, materials, and expendables

Table 4 Consumables, materials, and expendables

NAME	CAGE/REFERENCE	QUANTITY	REMARK
Wiping rags (clean, dry)	58536	AR	

Spares

Table 5 Spares

NAME	CAGE/REFERENCE	QUANTITY	REMARK
None			

Safety conditions

None

Procedure

NOTE

Periodic disassembling may be necessary for drying purposes.

- 1 Perform the applicable step(s) as follows:

NOTE

Whenever a cold weapon is placed indoors, allow it to warm to room temperature. After cleaning, dry thoroughly including any condensation that has formed.

- 1.1 For operations in extreme cold, perform the following steps:
 - 1.1.1 In climates where the temperature is consistently below 0°F, it is necessary to prepare the materiel for cold-weather operation. The Phun Gun should be cleaned.
 - 1.1.2 Operate the various controls through their entire range, at intervals, as required. This aids in keeping them from freezing in place and reduces the effort required to operate them.
 - 1.1.3 Materiel not in use and stored outside must be protected with a proper cover.
 - 1.1.4 See FM 31-70 Basic Cold Weather Manual for further information on operations in the Arctic.

NOTE

In hot climates whether humid, dry, or sandy; daily care must be exercised. In hot, dry climates where dust and sand prevail, the weapon will be wiped dry.

- 1.2 For operations in extreme heat, perform the following step:
 - 1.2.1 Perspiration contributes to corrosion, because it contains acids and salts. After handling Phun Gun, clean all surfaces with Wiping rags (clean, dry).

NOTE

In hot climates whether humid, dry, or sandy; daily care must be exercised. In hot, dry climates where dust and sand prevail, the weapon will be wiped dry. When leaving sandy terrain, wipe rifle clean at once.

- 1.3 For operations in dusty and sandy areas, perform the following steps:
 - 1.3.1 Clean and keep thoroughly dry. Do not lubricate. Even a light coat of oil will attract foreign matter, especially sand and dust, a potential cause of mechanical breakdown. During disassembly and assembly operations, shield parts whenever possible.
 - 1.3.2 When moving out of sandy terrain, clean as indicated.

NOTE

In hot climates whether humid, dry, or sandy, daily care must be exercised. In humid or rainy conditions, keep weapon clean when not in use.

- 1.4 For operations under rainy, humid conditions and salt water areas, perform the following step:
 1.4.1 Inspect the materiel more frequently when operating in hot, moist areas.

Requirements after job completion**Required conditions**

Table 6 Required conditions

ACTION/CONDITION	DATA MODULE/TECHNICAL PUBLICATION
None	

CHAPTER 3
FIELD MAINTENANCE INSTRUCTIONS

Phun Gun - Unpacking

References

Table 1 References

CHAP NO./DOCUMENT NO.	TITLE
None	

Preliminary requirements

Required conditions

Table 2 Required conditions

ACTION/CONDITION	DATA MODULE/TECHNICAL PUBLICATION
None	

Support equipment

Table 3 Support equipment

NAME	CAGE/REFERENCE	QUANTITY	REMARK
None			

Consumables, materials, and expendables

Table 4 Consumables, materials, and expendables

NAME	CAGE/REFERENCE	QUANTITY	REMARK
None			

Spares

Table 5 Spares

NAME	CAGE/REFERENCE	QUANTITY	REMARK
None			

Safety conditions

None

Procedure

- 1 When a new or reconditioned weapon is first received, it is the responsibility of the officer-in-charge to determine whether the weapon has been properly prepared for service by the supplying organization and whether it is in proper condition to perform its mission.
- 2 When a new or reconditioned Phun Gun is received, check for any shipping damage to packaging container and packaging material. Report any damage on SF 364, Report of Discrepancy (ROD), as prescribed in AR 735-11-2. Retain packaging materiel for future use.

Requirements after job completion

Required conditions

Table 6 Required conditions

ACTION/CONDITION	DATA MODULE/TECHNICAL PUBLICATION
None	

Phun Gun - Checking unpacked equipment

References

Table 1 References

CHAP NO./DOCUMENT NO.	TITLE
SF 361	Transportation Discrepancy Report

Checking Unpacked Equipment

LOCATION	ITEM	ACTION	REMARKS
WARNING			
<p>Before starting an inspection, be sure to clear the weapon. Do not actuate the trigger before clearing the weapon. Inspect the chamber to make sure it is empty and free of obstructions. Check to see there are no obstructions in the barrel and no ammunition is in position to be chambered.</p>			
Container	Phun Gun Basic issue items	Check for missing items.	
		1.1 Inspect the equipment for damage incurred during shipment.	If the equipment has been damaged, report the damage on SF 361 Transportation Discrepancy Report.
		1.2 Check the equipment against the packing slip to see if the shipment is complete.	Report all discrepancies in accordance with applicable service instructions (in other words, for Army instructions, see DA PAM 750-8 The Army Maintenance Management System (TAMMS) Users Manual).
Phun Gun	All parts	1 Field strip gun and inspect for missing parts.	Refer to PMC-S1000DGUN-1

LOCATION	ITEM	ACTION	REMARKS
			1005-OPI01-00 Phun Gun 30D Operator Maintenance Manual.
	2	Clean and lubricate.	Refer to PMC-S1000DGUN-1 1005-OPI01-00 Phun Gun 30D Operator Maintenance Manual.
	3	Reassemble.	Refer to PMC-S1000DGUN-1 1005-OPI01-00 Phun Gun 30D Operator Maintenance Manual.
	4	Test fire gun.	Refer to PMC-S1000DGUN-1 1005-OPI01-00 Phun Gun 30D Operator Maintenance Manual.
	5	Check to see whether the equipment has been modified.	DA PAM 25-30 Consolidated Index of Army Publications and Forms

Phun Gun - Assembly of equipment

References

Table 1 References

CHAP NO./DOCUMENT NO.	TITLE
None	

Preliminary requirements

Required conditions

Table 2 Required conditions

ACTION/CONDITION	DATA MODULE/TECHNICAL PUBLICATION
None	

Support equipment

Table 3 Support equipment

NAME	CAGE/REFERENCE	QUANTITY	REMARK
None			

Consumables, materials, and expendables

Table 4 Consumables, materials, and expendables

NAME	CAGE/REFERENCE	QUANTITY	REMARK
None			

Spares

Table 5 Spares

NAME	CAGE/REFERENCE	QUANTITY	REMARK
None			

Safety conditions

None

Procedure

- 1 Load darts into shells as shown in Figure 1.



ICN-07GB6-BELTASSY1-001-01

Figure 1. Load darts.

- 2 When all of the darts are loaded in the shells, snap together the belt assembly as shown in Figure 2 and Figure 3. The belt assembly is designed to snap apart and go back together again. The belt can be shortened or lengthened.

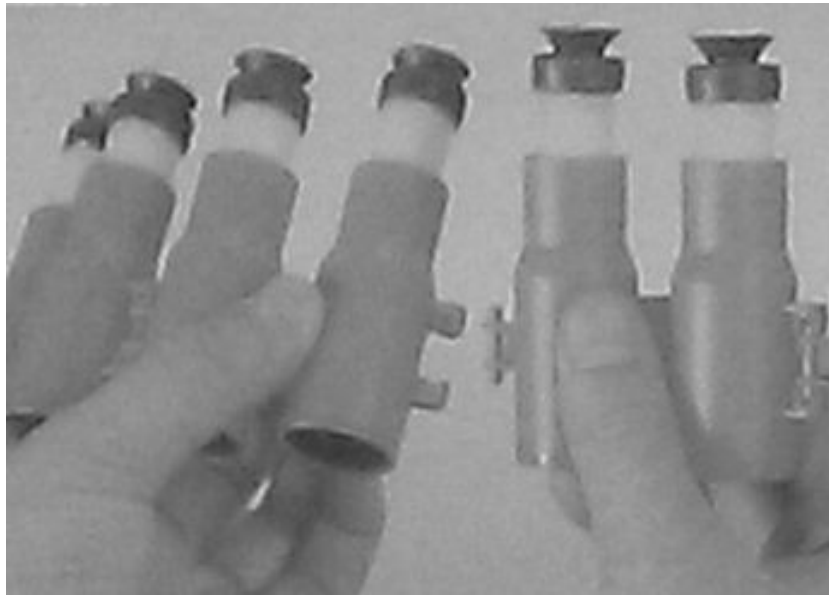

ICN-07GB6-BELTASSY3-001-01

Figure 2. Belt assembly.

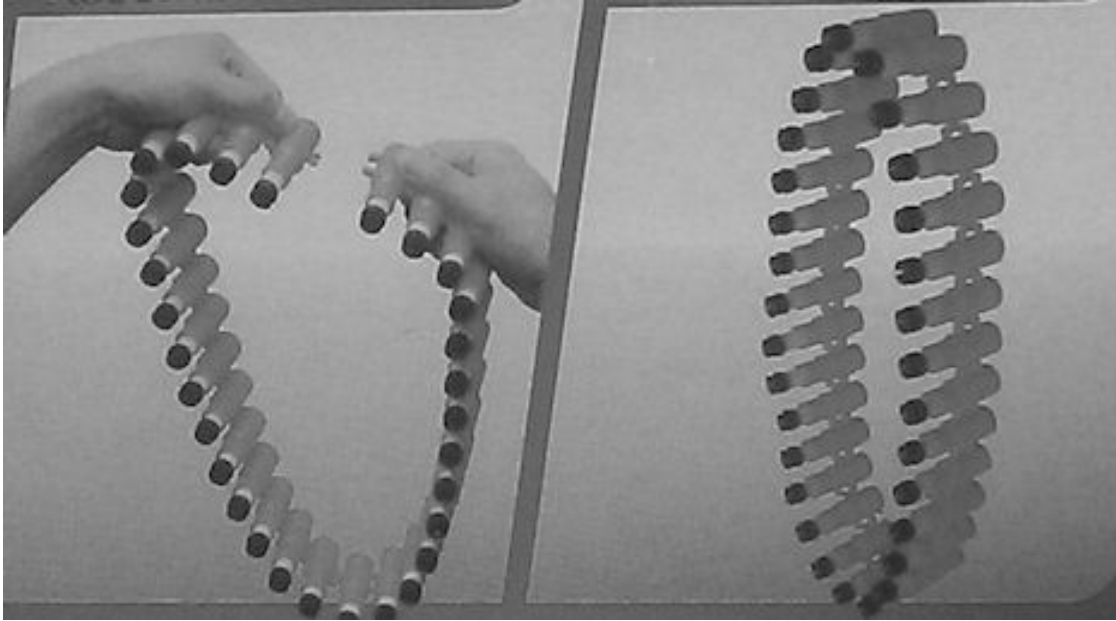

ICN-07GB6-BELTASSY2-001-01

Figure 3. Assembled belt assembly.

Requirements after job completion

Required conditions

Table 6 Required conditions

ACTION/CONDITION	DATA MODULE/TECHNICAL PUBLICATION
None	

Phun Gun - Procedures to activate ammunition

References

Table 1 References

CHAP NO./DOCUMENT NO.	TITLE
None	

Preliminary requirements

Required conditions

Table 2 Required conditions

ACTION/CONDITION	DATA MODULE/TECHNICAL PUBLICATION
Phun Gun must be positioned and secured so the safety plate is facing up	

Required persons

Table 3 Required persons

QUANTITY	CATEGORY	SKILL LEVEL	TRADE/TRADE CODE	ESTIMATED TIME
1	Maintainer			

Support equipment

Table 4 Support equipment

NAME	CAGE/REFERENCE	QUANTITY	REMARK
None			

Consumables, materials, and expendables

Table 5 Consumables, materials, and expendables

NAME	CAGE/REFERENCE	QUANTITY	REMARK
None			

Spares

Table 6 Spares

NAME	CAGE/REFERENCE	QUANTITY	REMARK
None			

Safety conditions

WARNING

Ensure belt assembly is not loaded.

WARNING

Make sure there is no dart in the barrel.

Procedure

WARNING

Do not aim at eyes or face.

WARNING

Do not point launcher at people or animals.

- 1 Pull trigger to discharge weapon. Refer to Figure 1.

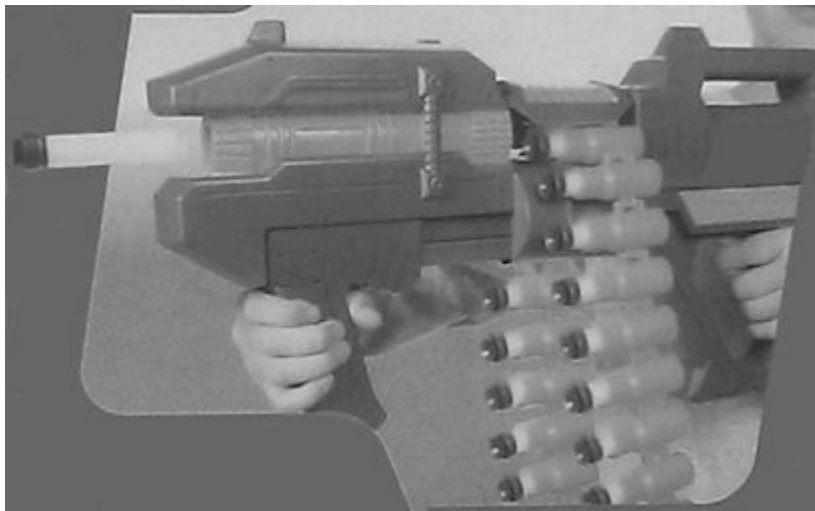

ICN-07GB6-GUNLOAD5-001-01

Figure 1. Discharge.

- 2 Refer to Phun Gun - Ammunition loading [S1000DGUN-0-00-00-00-00A-725A-A] for more information on ammunition loading.

Requirements after job completion

Required conditions

Table 7 Required conditions

ACTION/CONDITION	DATA MODULE/TECHNICAL PUBLICATION
None	

Phun Gun - PMCS introduction

References

Table 1 References

CHAP NO./DOCUMENT NO.	TITLE
None	

1 GENERAL

These services shall be performed by field maintenance personnel with the assistance, when practical, of the operators/crew, who will clean in accordance with Operator's Manual for Phun Gun 30D [S1000DGUN-91005-OPI01-00].

NOTE

Maintenance of some assemblies are not authorized by the Maintenance Allocation Chart (MAC) to field maintenance (refer to Phun Gun - MAC [S1000DGUN-0-00-00-00-00A-916A-A]). Ensure that no work is being accomplished beyond the scope authorized to field maintenance. Evacuate to sustainment maintenance for repairs when necessary.

Perform PMCS every 90 days to keep the weapon ready for use.

If the weapon has not been used for 90 days, PMCS in Operator's Manual for Phun Gun 30D [S1000DGUN-91005-OPI01-00] should also be performed.

The Phun Gun 30D is not enrolled in the Army Oil Analysis Program (AOAP). HARDTIME INTERVALS APPLY.

The PMCS procedures are contained in Phun Gun - PMCS [S1000DGUN-0-00-00-00-00A-200B-A]. They are arranged in logical sequence requiring a minimum amount of time and motion on the part of the persons performing them and are arranged so that there will be minimum interference between persons performing checks simultaneously on the same end item.

Information is presented in a tabular format with the following columns:

- 1 "Item No." column. Checks and services are numbered in disassembly sequence. This column shall be used as a source of item numbers for the TM Number column on DA Form 2404 Equipment Inspection and Maintenance Worksheet, in recording results of PMCS.
- 2 "Interval" column. This column provides the designated interval when each check is to be performed.
- 3 "Item to be Checked or Serviced" column. This column lists the item to be checked or serviced.
- 4 "Procedure" column. This column contains a brief description of the procedure by which the check is to be performed. It contains all the information required to accomplish the checks and services. Information marked SH indicates a specific equipment shortcoming and the procedure needed to correct the shortcoming.
- 5 "Not Fully Mission Capable If:" column. This column contains a brief statement of the condition (e.g., malfunction, shortage) that would cause the covered equipment to be less than fully ready to perform its assigned mission.

Phun Gun - PMCS

References

Table 1 References

CHAP NO./DOCUMENT NO.	TITLE
None	

Preventive Maintenance Checks and Services

ITEM NO.	INTERVAL	ITEM TO BE CHECKED OR SERVICED	PROCEDURE	EQUIPMENT NOT READY/AVAILABLE IF:
1	Before	Phun Gun 30D	All 1 Visually inspect Phun Gun for general appearance, condition, and operation. 2 Check to make sure weapon is properly assembled. 3 Repair or replace all authorized components ([insert applicable DM refs for maintenance (insertion, repair, disassembly, reassembly)]). If additional repair is needed, notify sustainment maintenance. 4 Check to ensure annual sustainment maintenance safety and serviceability inspection and gauging has been done and that the next gauging and inspection is scheduled. If annual gauging has not been performed within the last year, notify sustainment maintenance.	
2	Before	Barrel	1 Inspect barrel for cracks. 2 Make sure safety plate opens and closes freely.	Barrel is cracked.
3	Before	Trigger	Check trigger for free movement.	Trigger is not free.
4	Before	Dart belt	Inspect belt for cracks.	Belt is cracked.
5	Before	Slide assembly	Check slide assembly for free movement.	Slide assembly is not free.

Phun Gun - Test and inspection

References

Table 1 References

CHAP NO./DOCUMENT NO.	TITLE
None	

General information

Instructions

The following procedure shall be followed during or after assembly to ensure proper assembly of the weapon.

Preliminary requirements

Required conditions

Table 2 Required conditions

ACTION/CONDITION	DATA MODULE/TECHNICAL PUBLICATION
None	

Support equipment

Table 3 Support equipment

NAME	CAGE/REFERENCE	QUANTITY	REMARK
None			

Consumables, materials, and expendables

Table 4 Consumables, materials, and expendables

NAME	CAGE/REFERENCE	QUANTITY	REMARK
None			

Spares

Table 5 Spares

NAME	CAGE/REFERENCE	QUANTITY	REMARK
None			

Safety conditions

None

Procedure

WARNING

Before starting an inspection, be sure to clear the weapon. Do not actuate the trigger before clearing the weapon. Inspect the chamber to make sure it is empty and free of obstructions. Check to see there are no obstructions in the barrel and no ammunition is in position to be chambered.

- 1 Inspect the weapon as follows:
 - 1.1 Inspect the general condition of the gun.
 - 1.2 Inspect for missing, loose, or damaged parts.
 - 1.3 Make sure all controls operate properly.
 - 1.4 Inspect the weapon in accordance with the MAC. Refer to Phun Gun - MAC [S1000DGUN-0-00-00-00-00A-916A-A].
- 2 Test the weapon in accordance with the MAC. Refer to Phun Gun - MAC [S1000DGUN-0-00-00-00-00A-916A-A].

Requirements after job completion

Required conditions

Table 6 Required conditions

ACTION/CONDITION	DATA MODULE/TECHNICAL PUBLICATION
None	

Phun Gun - Ammunition loading

References

Table 1 References

CHAP NO./DOCUMENT NO.	TITLE
None	

Preliminary requirements

Required conditions

Table 2 Required conditions

ACTION/CONDITION	DATA MODULE/TECHNICAL PUBLICATION
Phun Gun must be positioned and secured so the safety plate is facing up	

Required persons

Table 3 Required persons

QUANTITY	CATEGORY	SKILL LEVEL	TRADE/TRADE CODE	ESTIMATED TIME
1	Maintainer			

Support equipment

Table 4 Support equipment

NAME	CAGE/REFERENCE	QUANTITY	REMARK
Belt assembly	77777	1	

Consumables, materials, and expendables

Table 5 Consumables, materials, and expendables

NAME	CAGE/REFERENCE	QUANTITY	REMARK
None			

Spares

Table 6 Spares

NAME	CAGE/REFERENCE	QUANTITY	REMARK
None			

Safety conditions

WARNING

Ensure belt assembly is not loaded.

WARNING

Make sure there is no dart in the barrel.

Procedure

- 1 Depress the safety plate release button to open the safety plate. Refer to Figure 1.



ICN-07GB6-GUNLOAD1-001-01

Figure 1. Safety plate release button.

- 2 Refer to Belt Assembly - Assembly procedure [S1000DGUN-0-00-AD-00-00A-710A-A]
- 3 Load completed Belt assembly into receiver assembly. Refer to Figure 2.



ICN-07GB6-GUNLOAD2-001-01

Figure 2. Loaded receiver assembly.

- 4 Secure safety plate. Refer to Figure 3.

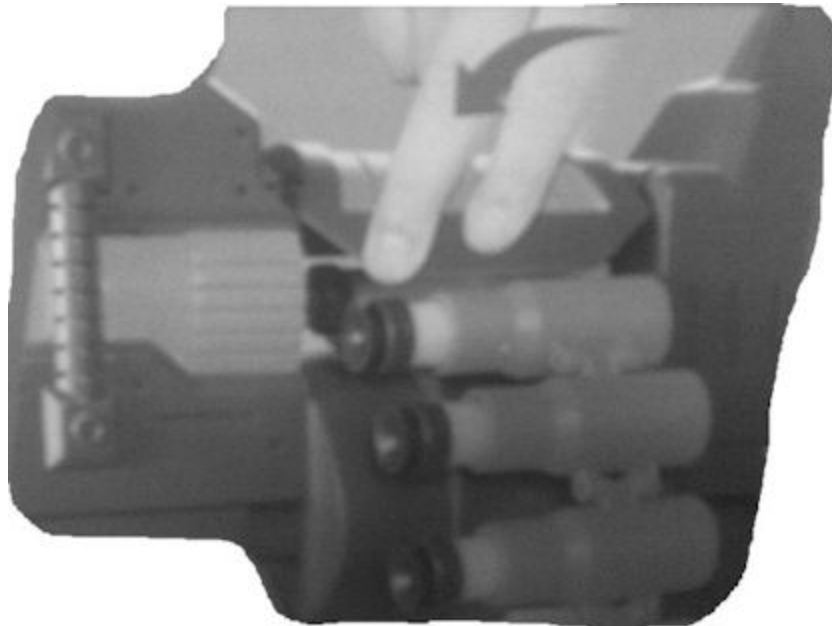

ICN-07GB6-GUNLOAD3-001-01

Figure 3. Secured safety plate.

- 5 Phun gun is now loaded and secured. Refer to Figure 4. Refer to Phun Gun - Procedures to activate ammunition [S1000DGUN-0-00-00-00-00A-120G-A].



ICN-07GB6-GUNLOAD5-001-01

Figure 4. Secure and ready to fire.

Requirements after job completion

Required conditions

Table 7 Required conditions

ACTION/CONDITION	DATA MODULE/TECHNICAL PUBLICATION
Safety plate is securely closed	

Phun Gun - Procedures to activate ammunition

References

Table 1 References

CHAP NO./DOCUMENT NO.	TITLE
None	

Preliminary requirements

Required conditions

Table 2 Required conditions

ACTION/CONDITION	DATA MODULE/TECHNICAL PUBLICATION
Phun Gun must be positioned and secured so the safety plate is facing up	

Required persons

Table 3 Required persons

QUANTITY	CATEGORY	SKILL LEVEL	TRADE/TRADE CODE	ESTIMATED TIME
1	Maintainer			

Support equipment

Table 4 Support equipment

NAME	CAGE/REFERENCE	QUANTITY	REMARK
None			

Consumables, materials, and expendables

Table 5 Consumables, materials, and expendables

NAME	CAGE/REFERENCE	QUANTITY	REMARK
None			

Spares

Table 6 Spares

NAME	CAGE/REFERENCE	QUANTITY	REMARK
None			

Safety conditions

WARNING

Ensure belt assembly is not loaded.

WARNING

Make sure there is no dart in the barrel.

Procedure

WARNING

Do not aim at eyes or face.

WARNING

Do not point launcher at people or animals.

- 1 Pull trigger to discharge weapon. Refer to Figure 1.

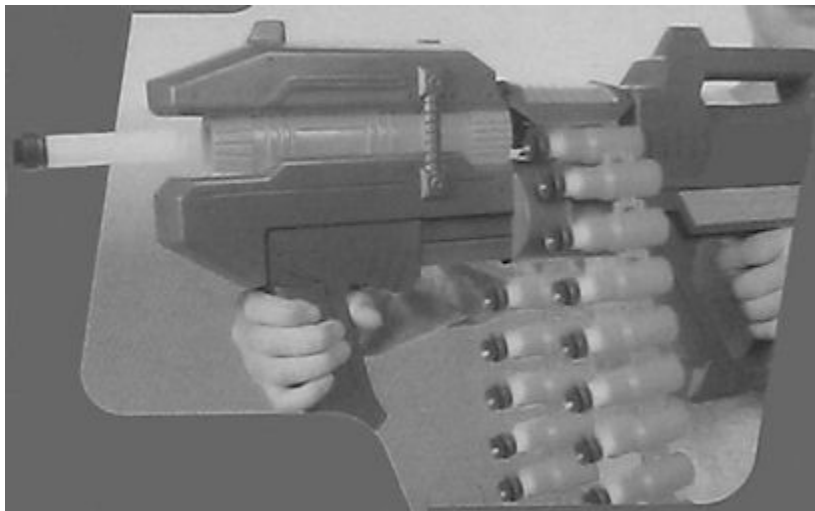

ICN-07GB6-GUNLOAD5-001-01

Figure 1. Discharge.

- 2 Refer to Phun Gun - Ammunition loading [S1000DGUN-0-00-00-00-00A-725A-A] for more information on ammunition loading.

Requirements after job completion

Required conditions

Table 7 Required conditions

ACTION/CONDITION	DATA MODULE/TECHNICAL PUBLICATION
None	

Phun Gun - Ammunition unloading

References

Table 1 References

CHAP NO./DOCUMENT NO.	TITLE
None	

Preliminary requirements

Required conditions

Table 2 Required conditions

ACTION/CONDITION	DATA MODULE/TECHNICAL PUBLICATION
None	

Support equipment

Table 3 Support equipment

NAME	CAGE/REFERENCE	QUANTITY	REMARK
None			

Consumables, materials, and expendables

Table 4 Consumables, materials, and expendables

NAME	CAGE/REFERENCE	QUANTITY	REMARK
None			

Spares

Table 5 Spares

NAME	CAGE/REFERENCE	QUANTITY	REMARK
None			

Safety conditions

WARNING

Make sure there is no dart in the barrel.

Procedure

WARNING

Unload the phun gun when not in use.

- 1 Carefully remove the belt assembly by one of the methods below:
- 1.1 Optionally unsnap two shells and remove belt, or



ICN-07GB6-DARTS1-001-01

Figure 1. Cartridges.

- 1.2 Open the safety plate and slide entire belt over barrel to remove belt.

Requirements after job completion

Required conditions

Table 6 Required conditions

ACTION/CONDITION	DATA MODULE/TECHNICAL PUBLICATION
None	

Phun Gun - Other procedures to clean

References

Table 1 References

CHAP NO./DOCUMENT NO.	TITLE
None	

Preliminary requirements

Required conditions

Table 2 Required conditions

ACTION/CONDITION	DATA MODULE/TECHNICAL PUBLICATION
None	

Support equipment

Table 3 Support equipment

NAME	CAGE/REFERENCE	QUANTITY	REMARK
None			

Consumables, materials, and expendables

Table 4 Consumables, materials, and expendables

NAME	CAGE/REFERENCE	QUANTITY	REMARK
Wiping rags (clean, dry)	58536	AR	

Spares

Table 5 Spares

NAME	CAGE/REFERENCE	QUANTITY	REMARK
None			

Safety conditions

None

Procedure

- 1 Wipe all accessible components with a Wiping rags (clean, dry). Replace the Wiping rags (clean, dry) as needed.

Requirements after job completion

Required conditions

Table 6 Required conditions

ACTION/CONDITION	DATA MODULE/TECHNICAL PUBLICATION
None	

Receiver Assembly - Inspect

References

Table 1 References

CHAP NO./DOCUMENT NO.	TITLE
None	

Preliminary requirements

Required conditions

Table 2 Required conditions

ACTION/CONDITION	DATA MODULE/TECHNICAL PUBLICATION
None	

Support equipment

Table 3 Support equipment

NAME	CAGE/REFERENCE	QUANTITY	REMARK
None			

Consumables, materials, and expendables

Table 4 Consumables, materials, and expendables

NAME	CAGE/REFERENCE	QUANTITY	REMARK
None			

Spares

Table 5 Spares

NAME	CAGE/REFERENCE	QUANTITY	REMARK
None			

Safety conditions

None

Procedure

- 1 Visually check receiver for straightness. If bent, notify depot maintenance.



ICN-07GB6-RCVRASSY-001-01

Figure 1. Receiver assembly.

2 Repair is by replacement of authorized parts.

Requirements after job completion

Required conditions

Table 6 Required conditions

ACTION/CONDITION	DATA MODULE/TECHNICAL PUBLICATION
None	

Barrel Assembly - Inspect

References

Table 1 References

CHAP NO./DOCUMENT NO.	TITLE
None	

Preliminary requirements

Required conditions

Table 2 Required conditions

ACTION/CONDITION	DATA MODULE/TECHNICAL PUBLICATION
None	

Support equipment

Table 3 Support equipment

NAME	CAGE/REFERENCE	QUANTITY	REMARK
None			

Consumables, materials, and expendables

Table 4 Consumables, materials, and expendables

NAME	CAGE/REFERENCE	QUANTITY	REMARK
None			

Spares

Table 5 Spares

NAME	CAGE/REFERENCE	QUANTITY	REMARK
None			

Safety conditions

None

Procedure

- 1 Visually check barrel for straightness. If bent, notify depot maintenance.
- 2 Repair is by replacement of authorized parts.

Requirements after job completion

Required conditions

Table 6 Required conditions

ACTION/CONDITION	DATA MODULE/TECHNICAL PUBLICATION
None	

Trigger - Adjust

References

Table 1 References

CHAP NO./DOCUMENT NO.	TITLE
None	

General information

Instructions

This procedure shall be followed when the safety plate release button is out of adjustment.

Preliminary requirements

Required conditions

Table 2 Required conditions

ACTION/CONDITION	DATA MODULE/TECHNICAL PUBLICATION
Phun Gun is secured so the safety plate is facing up	

Required persons

Table 3 Required persons

QUANTITY	CATEGORY	SKILL LEVEL	TRADE/TRADE CODE	ESTIMATED TIME
1	Maintainer			0.25 hr

Support equipment

Table 4 Support equipment

NAME	CAGE/REFERENCE	QUANTITY	REMARK
None			

Consumables, materials, and expendables

Table 5 Consumables, materials, and expendables

NAME	CAGE/REFERENCE	QUANTITY	REMARK
None			

Spares

Table 6 Spares

NAME	CAGE/REFERENCE	QUANTITY	REMARK
None			

Safety conditions**WARNING**

Ensure the Phun Gun belt assembly is not loaded.

WARNING

Make sure no dart is in the barrel.

Procedure

- 1 Adjust the sensitivity of the trigger to prevent accidental discharge.

Requirements after job completion**Required conditions**

Table 7 Required conditions

ACTION/CONDITION	DATA MODULE/TECHNICAL PUBLICATION
None	

Belt Assembly - Assembly procedure

References

Table 1 References

CHAP NO./DOCUMENT NO.	TITLE
None	

Preliminary requirements

Required conditions

Table 2 Required conditions

ACTION/CONDITION	DATA MODULE/TECHNICAL PUBLICATION
None	

Support equipment

Table 3 Support equipment

NAME	CAGE/REFERENCE	QUANTITY	REMARK
None			

Consumables, materials, and expendables

Table 4 Consumables, materials, and expendables

NAME	CAGE/REFERENCE	QUANTITY	REMARK
Darts	77777	30	

Spares

Table 5 Spares

NAME	CAGE/REFERENCE	QUANTITY	REMARK
None			

Safety conditions

WARNING

Ensure belt assembly is not loaded.

WARNING

Make sure there is no dart in the barrel.

Procedure

- Each dart (1) also includes a dart tip (2).

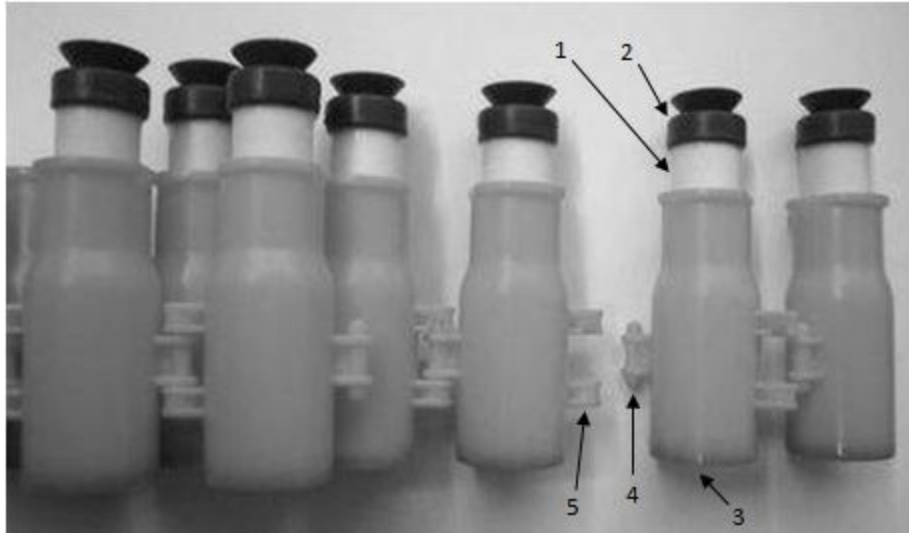

ICN-07GB6-DARTS2-001-01

Figure 1. Cartridges.

- 2 The entire dart slips into the shell (3). Refer to Figure 1 and Figure 2.



ICN-07GB6-BELTASSY1-001-01

Figure 2. Load shell.

- 3 Insert flange (4) into flange hinge (5). Refer to Figure 1 and Figure 3.

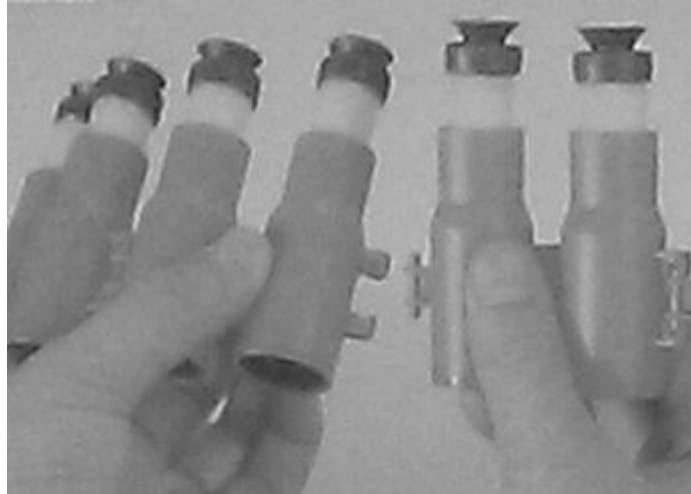

ICN-07GB6-BELTASSY3-001-01

Figure 3. Belt assembly.

- 4 Repeat Step 3 until belt is complete, as shown in Figure 4.

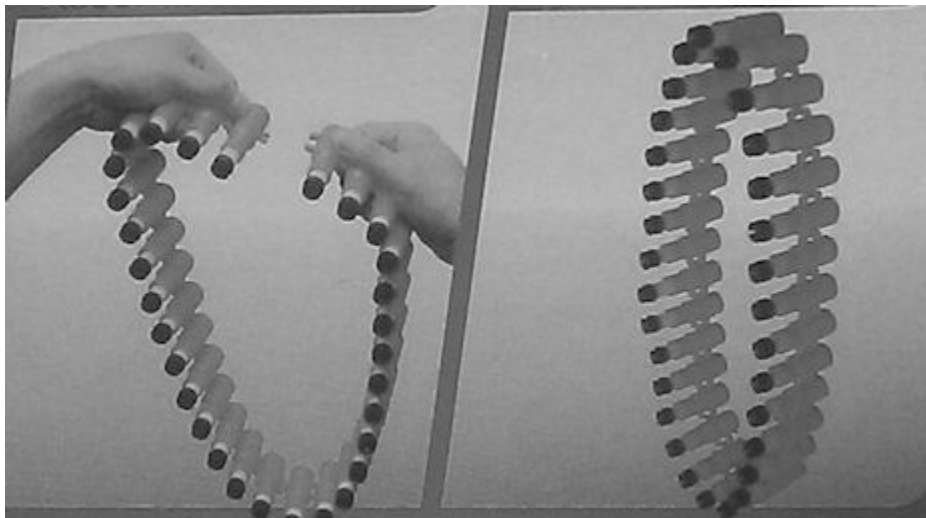

ICN-07GB6-BELTASSY2-001-01

Figure 4. Completed belt assembly.**NOTE**

The belt assembly is designed to snap apart and go back together again.
The belt can be shortened or lengthened.

- 5 Slightly twist the flange and flange hinge in order to separate, as shown in Figure 5. Adjust the belt as necessary. Refer to Step 3 to reconnect the belt.



ICN-07GB6-BELTASSY4-001-01

Figure 5. Belt flange separation.

Requirements after job completion**Required conditions**

Table 6 Required conditions

ACTION/CONDITION	DATA MODULE/TECHNICAL PUBLICATION
None	

Belt Assembly - Adjust

References

Table 1 References

CHAP NO./DOCUMENT NO.	TITLE
None	

General information

Instructions

This procedure shall be followed when the belt is out of adjustment.

Preliminary requirements

Required conditions

Table 2 Required conditions

ACTION/CONDITION	DATA MODULE/TECHNICAL PUBLICATION
Phun Gun is secured so the safety plate is facing up	

Required persons

Table 3 Required persons

QUANTITY	CATEGORY	SKILL LEVEL	TRADE/TRADE CODE	ESTIMATED TIME
1	Maintainer			0.25 hr

Support equipment

Table 4 Support equipment

NAME	CAGE/REFERENCE	QUANTITY	REMARK
None			

Consumables, materials, and expendables

Table 5 Consumables, materials, and expendables

NAME	CAGE/REFERENCE	QUANTITY	REMARK
None			

Spares

Table 6 Spares

NAME	CAGE/REFERENCE	QUANTITY	REMARK
None			

Safety conditions

WARNING

Ensure the Phun Gun belt assembly is not loaded.

WARNING

Make sure no dart is in the barrel.

Procedure

- 1 Release the safety plate.
- 2 Adjust the belt so that it is inline with the receiver assembly and with the barrel.
- 3 Close the safety plate.

Requirements after job completion

Required conditions

Table 7 Required conditions

ACTION/CONDITION	DATA MODULE/TECHNICAL PUBLICATION
Safety plate is secured	

Belt Assembly - Inspect

References

Table 1 References

CHAP NO./DOCUMENT NO.	TITLE
None	

Preliminary requirements

Required conditions

Table 2 Required conditions

ACTION/CONDITION	DATA MODULE/TECHNICAL PUBLICATION
None	

Support equipment

Table 3 Support equipment

NAME	CAGE/REFERENCE	QUANTITY	REMARK
None			

Consumables, materials, and expendables

Table 4 Consumables, materials, and expendables

NAME	CAGE/REFERENCE	QUANTITY	REMARK
None			

Spares

Table 5 Spares

NAME	CAGE/REFERENCE	QUANTITY	REMARK
None			

Safety conditions

None

Procedure

- 1 Visually check belt assembly for flange separation. If separation has occurred, refer to Belt Assembly - Assembly procedure [S1000DGUN-0-00-AD-00-00A-710A-A] for further information.
- 2 Repair is by replacement of authorized parts.

Requirements after job completion

Required conditions

Table 6 Required conditions

ACTION/CONDITION	DATA MODULE/TECHNICAL PUBLICATION
None	

Slide Assembly - Inspect

References

Table 1 References

CHAP NO./DOCUMENT NO.	TITLE
None	

Preliminary requirements

Required conditions

Table 2 Required conditions

ACTION/CONDITION	DATA MODULE/TECHNICAL PUBLICATION
None	

Support equipment

Table 3 Support equipment

NAME	CAGE/REFERENCE	QUANTITY	REMARK
None			

Consumables, materials, and expendables

Table 4 Consumables, materials, and expendables

NAME	CAGE/REFERENCE	QUANTITY	REMARK
None			

Spares

Table 5 Spares

NAME	CAGE/REFERENCE	QUANTITY	REMARK
None			

Safety conditions

None

Procedure

- 1 Visually check for broken, missing, or damaged parts.
- 2 Inspect all components for bends, breaks, or excessive wear.
- 3 Repair is by replacement of authorized parts.

Requirements after job completion**Required conditions****Table 6 Required conditions**

ACTION/CONDITION	DATA MODULE/TECHNICAL PUBLICATION
None	

Slide Assembly - Align

References

Table 1 References

CHAP NO./DOCUMENT NO.	TITLE
None	

Preliminary requirements

Required conditions

Table 2 Required conditions

ACTION/CONDITION	DATA MODULE/TECHNICAL PUBLICATION
None	

Required persons

Table 3 Required persons

QUANTITY	CATEGORY	SKILL LEVEL	TRADE/TRADE CODE	ESTIMATED TIME
1	Maintainer			

Support equipment

Table 4 Support equipment

NAME	CAGE/REFERENCE	QUANTITY	REMARK
None			

Consumables, materials, and expendables

Table 5 Consumables, materials, and expendables

NAME	CAGE/REFERENCE	QUANTITY	REMARK
None			

Spares

Table 6 Spares

NAME	CAGE/REFERENCE	QUANTITY	REMARK
None			

Safety conditions

WARNING

Ensure belt assembly is not loaded.

WARNING

Make sure no dart is in the barrel.

Procedure

NOTE

Slide assembly movement should be smooth along the slide assembly track.

- 1 Push and pull slide assembly to ensure track alignment.



ICN-07GB6-GUNLOAD4-001-01

Figure 1. Slide assembly.

Requirements after job completion

Required conditions

Table 7 Required conditions

ACTION/CONDITION	DATA MODULE/TECHNICAL PUBLICATION
None	

Slide Assembly - Removal procedure

References

Table 1 References

CHAP NO./DOCUMENT NO.	TITLE
None	

Preliminary requirements

Required conditions

Table 2 Required conditions

ACTION/CONDITION	DATA MODULE/TECHNICAL PUBLICATION
None	

Required persons

Table 3 Required persons

QUANTITY	CATEGORY	SKILL LEVEL	TRADE/TRADE CODE	ESTIMATED TIME
1	Maintainer			

Support equipment

Table 4 Support equipment

NAME	CAGE/REFERENCE	QUANTITY	REMARK
None			

Consumables, materials, and expendables

Table 5 Consumables, materials, and expendables

NAME	CAGE/REFERENCE	QUANTITY	REMARK
None			

Spares

Table 6 Spares

NAME	CAGE/REFERENCE	QUANTITY	REMARK
None			

Safety conditions

WARNING



Ensure the belt assembly is not loaded.

Be sure to clear the weapon before any work is performed on it. Clearing consists of unloading the weapon and visually inspecting weapon and chamber to ensure all rounds have been removed.

Procedure

- 1 Loosen screws (1, 2, 3) on slide assembly as shown in Figure 1.

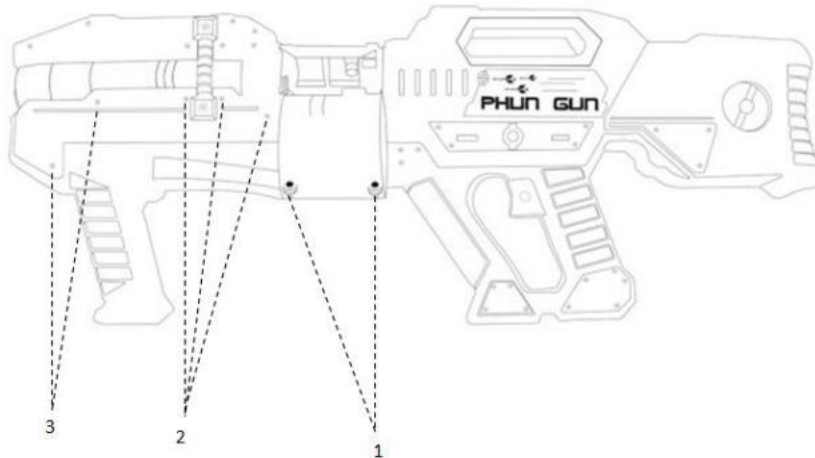

ICN-07GB6-SLIDEASSY1-001-01

Figure 1. Slide assembly.

- 2 Carefully, slip the slide assembly from the gun casing.
- 3 When the slide assembly has been removed, proceed to Slide Assembly - Replace [S1000DGUN-0-00-AE-00-00A-685C-A].

Requirements after job completion

Required conditions

Table 7 Required conditions

ACTION/CONDITION	DATA MODULE/TECHNICAL PUBLICATION
None	

Slide Assembly - Repair

References

Table 1 References

CHAP NO./DOCUMENT NO.	TITLE
None	

Preliminary requirements

Required conditions

Table 2 Required conditions

ACTION/CONDITION	DATA MODULE/TECHNICAL PUBLICATION
Phun Gun must be positioned and secured so the safety plate is facing up	

Required persons

Table 3 Required persons

QUANTITY	CATEGORY	SKILL LEVEL	TRADE/TRADE CODE	ESTIMATED TIME
1	Maintainer			

Support equipment

Table 4 Support equipment

NAME	CAGE/REFERENCE	QUANTITY	REMARK
None			

Consumables, materials, and expendables

Table 5 Consumables, materials, and expendables

NAME	CAGE/REFERENCE	QUANTITY	REMARK
None			

Spares

Table 6 Spares

NAME	CAGE/REFERENCE	QUANTITY	REMARK
None			

Safety conditions

WARNING

Ensure the belt assembly is not loaded.

WARNING

Make sure to clear the weapon before any work is performed on it. Clearing consists of unloading the weapon and visually inspecting weapon and chamber to ensure all rounds have been removed.

Procedure

- 1 Repair slide assembly when slide assembly is disconnected from the slide assembly track.
- 2 Twist to reconnect.
- 3 When the slide assembly has been repaired, proceed to Slide Assembly - Align [S1000DGUN-0-00-AE-00-00A-272A-A].

Requirements after job completion**Required conditions**

Table 7 Required conditions

ACTION/CONDITION	DATA MODULE/TECHNICAL PUBLICATION
None	

Slide Assembly - Replace

References

Table 1 References

CHAP NO./DOCUMENT NO.	TITLE
None	

Preliminary requirements

Required conditions

Table 2 Required conditions

ACTION/CONDITION	DATA MODULE/TECHNICAL PUBLICATION
None	

Required persons

Table 3 Required persons

QUANTITY	CATEGORY	SKILL LEVEL	TRADE/TRADE CODE	ESTIMATED TIME
1	Maintainer			

Support equipment

Table 4 Support equipment

NAME	CAGE/REFERENCE	QUANTITY	REMARK
None			

Consumables, materials, and expendables

Table 5 Consumables, materials, and expendables

NAME	CAGE/REFERENCE	QUANTITY	REMARK
None			

Spares

Table 6 Spares

NAME	CAGE/REFERENCE	QUANTITY	REMARK
None			

Safety conditions

WARNING



Ensure the belt assembly is not loaded.

Be sure to clear the weapon before any work is performed on it. Clearing consists of unloading the weapon and visually inspecting weapon and chamber to ensure all rounds have been removed.

Procedure

- 1 Slip the new slide assembly back into position.
- 2 Tighten screws (1, 2, 3) as shown in Figure 1.

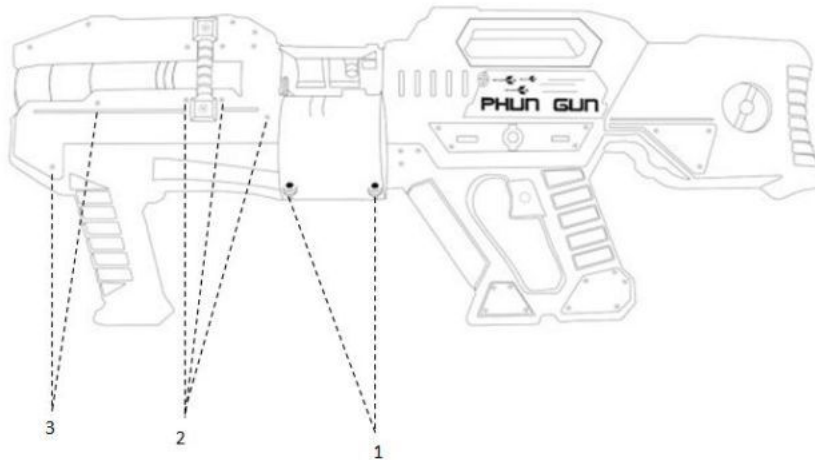

ICN-07GB6-SLIDEASSY1-001-01

Figure 1. Slide assembly.

- 3 When slide assembly is secured, proceed to Phun Gun - Test and inspection [S1000DGUN-0-00-00-00-00A-300B-A].

Requirements after job completion

Required conditions

Table 7 Required conditions

ACTION/CONDITION	DATA MODULE/TECHNICAL PUBLICATION
None	

Safety Plate - Align

References

Table 1 References

CHAP NO./DOCUMENT NO.	TITLE
None	

General information

Instructions

The following procedure shall be followed when the safety plate release button is out of alignment.

Preliminary requirements

Required conditions

Table 2 Required conditions

ACTION/CONDITION	DATA MODULE/TECHNICAL PUBLICATION
Phun Gun must be positioned and secured so the safety plate is facing up	

Required persons

Table 3 Required persons

QUANTITY	CATEGORY	SKILL LEVEL	TRADE/TRADE CODE	ESTIMATED TIME
1	Maintainer			

Support equipment

Table 4 Support equipment

NAME	CAGE/REFERENCE	QUANTITY	REMARK
None			

Consumables, materials, and expendables

Table 5 Consumables, materials, and expendables

NAME	CAGE/REFERENCE	QUANTITY	REMARK
None			

Spares

Table 6 Spares

NAME	CAGE/REFERENCE	QUANTITY	REMARK
None			

Safety conditions

WARNING

Make sure there is no dart in the barrel.

Procedure

- 1 Ensure safety plate closes securely and is aligned properly with belt assembly.

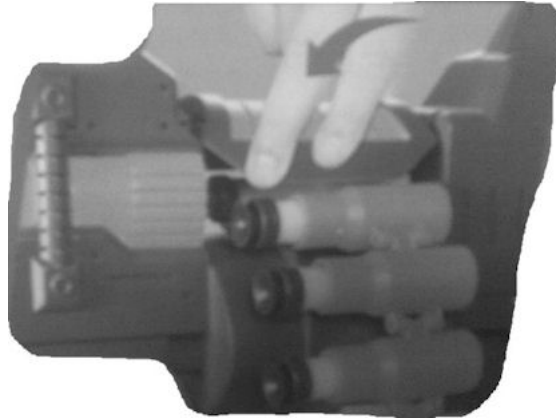

ICN-07GB6-GUNLOAD3-001-01

Figure 1. Safety plate.

Requirements after job completion

Required conditions

Table 7 Required conditions

ACTION/CONDITION	DATA MODULE/TECHNICAL PUBLICATION
None	

Safety Plate - Adjust

References

Table 1 References

CHAP NO./DOCUMENT NO.	TITLE
None	

General information

Instructions

This procedure shall be followed when the safety plate is out of adjustment.

Preliminary requirements

Required conditions

Table 2 Required conditions

ACTION/CONDITION	DATA MODULE/TECHNICAL PUBLICATION
Phun Gun is secured so the safety plate is facing up	

Required persons

Table 3 Required persons

QUANTITY	CATEGORY	SKILL LEVEL	TRADE/TRADE CODE	ESTIMATED TIME
1	Maintainer			0.25 hr

Support equipment

Table 4 Support equipment

NAME	CAGE/REFERENCE	QUANTITY	REMARK
None			

Consumables, materials, and expendables

Table 5 Consumables, materials, and expendables

NAME	CAGE/REFERENCE	QUANTITY	REMARK
None			

Spares

Table 6 Spares

NAME	CAGE/REFERENCE	QUANTITY	REMARK
None			

Safety conditions

WARNING

Ensure the Phun Gun belt assembly is not loaded.

WARNING

Make sure no dart is in the barrel.

Procedure

- 1 Release the safety plate.
- 2 Adjust the screw and ensure the plate is inline with the barrel.
- 3 Close the safety plate.

Requirements after job completion

Required conditions

Table 7 Required conditions

ACTION/CONDITION	DATA MODULE/TECHNICAL PUBLICATION
Safety plate is secured	

Safety Plate - Replace

References

Table 1 References

CHAP NO./DOCUMENT NO.	TITLE
None	

Preliminary requirements

Required conditions

Table 2 Required conditions

ACTION/CONDITION	DATA MODULE/TECHNICAL PUBLICATION
Phun Gun must be positioned and secured so the safety plate is facing up	

Required persons

Table 3 Required persons

QUANTITY	CATEGORY	SKILL LEVEL	TRADE/TRADE CODE	ESTIMATED TIME
1	Maintainer			0.25 hr

Support equipment

Table 4 Support equipment

NAME	CAGE/REFERENCE	QUANTITY	REMARK
None			

Consumables, materials, and expendables

Table 5 Consumables, materials, and expendables

NAME	CAGE/REFERENCE	QUANTITY	REMARK
None			

Spares

Table 6 Spares

NAME	CAGE/REFERENCE	QUANTITY	REMARK
None			

Safety conditions

WARNING

Ensure the belt assembly is not loaded.

WARNING

Make sure no dart is in the barrel.

Procedure

- 1 Place the Phun Gun so that it is vertical.
- 2 Open the safety plate.



ICN-07GB6-GUNLOAD1-001-01

Figure 1. Safety plate.

- 3 Remove all the screws to get the safety plate off. Retain screws for reinsertion.
- 4 Carefully lift off facing (top) half of Phun Gun casing being careful to not disrupt the inner mechanism when removing the facing half.
- 5 Carefully lay facing half to the side.
- 6 Locate the safety plate hinge.
- 7 Lift the safety plate hinge bolt from its casing. Discard the damaged safety plate.
- 8 Insert a replacement safety plate.
 - 8.1 Angle the safety plate hinge into the casing.
 - 8.2 Straighten the safety plate until the hinge snaps into the casing.
 - 8.3 Do not close the safety plate.
- 9 Place the facing half of the phun gun casing on the lower half of the casing. Verify that all screw holes are lined up.

-
- 10 Insert each screw into a screw hole.
- 11 Turn each screw one full turn.

CAUTION

When driving the screws, be careful to not strip the screw hole threads.

- 12 If all screws start without resistance, continue driving each screw until tight. If a screw encounters resistance, back out each screw and reseal the facing half by returning to Step 9.

Requirements after job completion

Required conditions

Table 7 Required conditions

ACTION/CONDITION	DATA MODULE/TECHNICAL PUBLICATION
Safety plate is colsed	

Safety Plate Release Button - Adjust

References

Table 1 References

CHAP NO./DOCUMENT NO.	TITLE
None	

General information

Instructions

This procedure shall be followed when the safety plate release button is out of adjustment.

Preliminary requirements

Required conditions

Table 2 Required conditions

ACTION/CONDITION	DATA MODULE/TECHNICAL PUBLICATION
Phun Gun is secured so the safety plate is facing up	

Required persons

Table 3 Required persons

QUANTITY	CATEGORY	SKILL LEVEL	TRADE/TRADE CODE	ESTIMATED TIME
1	Maintainer			0.25 hr

Support equipment

Table 4 Support equipment

NAME	CAGE/REFERENCE	QUANTITY	REMARK
Small arms tool kit	06060	1	Only required tool needed from kit: Screwdriver, cross tip #1 Phillips 3/8 SQ DR.

Consumables, materials, and expendables

Table 5 Consumables, materials, and expendables

NAME	CAGE/REFERENCE	QUANTITY	REMARK
None			

Spares

Table 6 Spares

NAME	CAGE/REFERENCE	QUANTITY	REMARK
None			

Safety conditions

WARNING

Ensure the Phun Gun belt assembly is not loaded.

WARNING

Make sure there is no dart in the barrel.

Procedure

- 1 Locate the safety plate release button.



ICN-07GB6-GUNLOAD1-001-01

Figure 1. Release button, safety plate.

- 2 Slide the safety plate release button forward. The safety plate will open.
- 3 With the release button held in the forward position, locate the adjustment screw immediately behind it in the safety plate release button track.
- 4 If the safety plate release button is too tight, skip to Step 4.2, if it is too loose continue with Step 4.1.
- 4.1 Using the Small arms tool kit, turn the adjustment screw clockwise until the safety plate release button slides properly. Proceed to Step 5.
- 4.2 Using the Small arms tool kit, turn the adjustment screw counter-clockwise until the safety plate release button slides properly.

-
- 5 Allow the safety plate release button to slide back to its resting position (covering the adjustment screw).
 - 6 Close the safety plate.
 - 7 Slide the safety plate release button. The safety plate should open. Confirm that the button operates properly. If the safety plate does not open properly return to Step 3.

Requirements after job completion

Required conditions

Table 7 Required conditions

ACTION/CONDITION	DATA MODULE/TECHNICAL PUBLICATION
Safety plate is closed	

Phun Gun - Ammunition loading

References

Table 1 References

CHAP NO./DOCUMENT NO.	TITLE
None	

Preliminary requirements

Required conditions

Table 2 Required conditions

ACTION/CONDITION	DATA MODULE/TECHNICAL PUBLICATION
Phun Gun must be positioned and secured so the safety plate is facing up	

Required persons

Table 3 Required persons

QUANTITY	CATEGORY	SKILL LEVEL	TRADE/TRADE CODE	ESTIMATED TIME
1	Maintainer			

Support equipment

Table 4 Support equipment

NAME	CAGE/REFERENCE	QUANTITY	REMARK
Belt assembly	77777	1	

Consumables, materials, and expendables

Table 5 Consumables, materials, and expendables

NAME	CAGE/REFERENCE	QUANTITY	REMARK
None			

Spares

Table 6 Spares

NAME	CAGE/REFERENCE	QUANTITY	REMARK
None			

Safety conditions

WARNING

Ensure belt assembly is not loaded.

WARNING

Make sure there is no dart in the barrel.

Procedure

- 1 Depress the safety plate release button to open the safety plate. Refer to Figure 1.



ICN-07GB6-GUNLOAD1-001-01

Figure 1. Safety plate release button.

- 2 Refer to Belt Assembly - Assembly procedure [S1000DGUN-0-00-AD-00-00A-710A-A]
- 3 Load completed Belt assembly into receiver assembly. Refer to Figure 2.

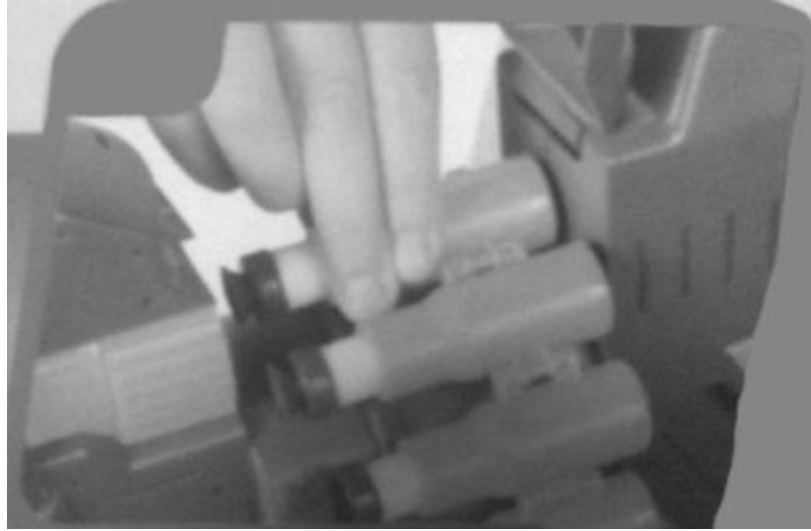

ICN-07GB6-GUNLOAD2-001-01

Figure 2. Loaded receiver assembly.

- 4 Secure safety plate. Refer to Figure 3.

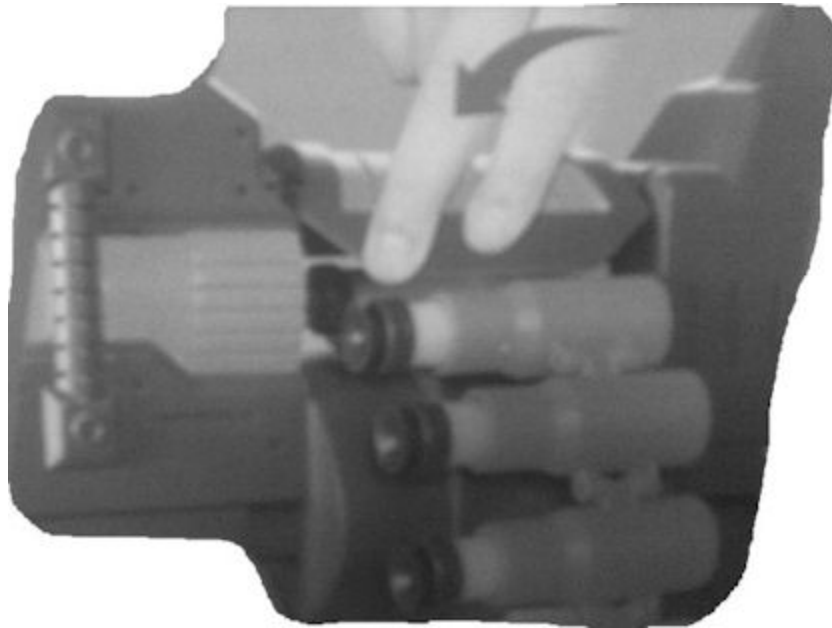

ICN-07GB6-GUNLOAD3-001-01

Figure 3. Secured safety plate.

- 5 Phun gun is now loaded and secured. Refer to Figure 4. Refer to Phun Gun - Procedures to activate ammunition [S1000DGUN-0-00-00-00-00A-120G-A].

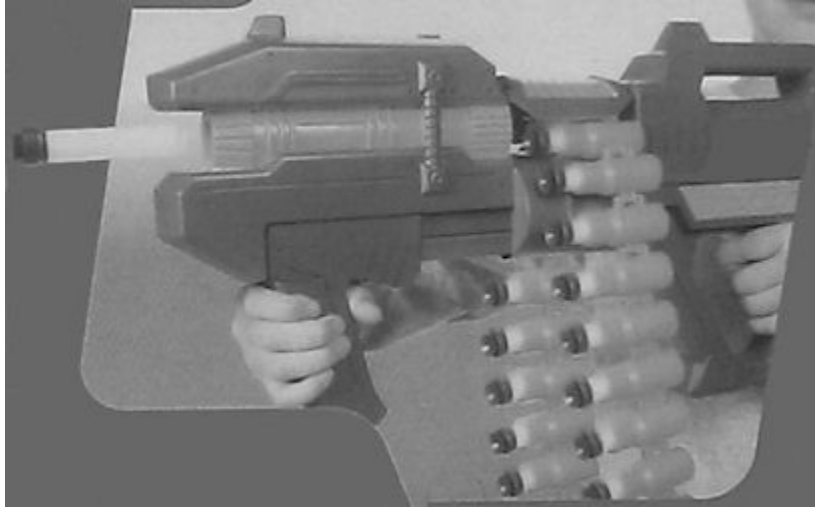

ICN-07GB6-GUNLOAD5-001-01

Figure 4. Secure and ready to fire.

Requirements after job completion

Required conditions

Table 7 Required conditions

ACTION/CONDITION	DATA MODULE/TECHNICAL PUBLICATION
Safety plate is securely closed	

Phun Gun - Ammunition unloading

References

Table 1 References

CHAP NO./DOCUMENT NO.	TITLE
None	

Preliminary requirements

Required conditions

Table 2 Required conditions

ACTION/CONDITION	DATA MODULE/TECHNICAL PUBLICATION
None	

Support equipment

Table 3 Support equipment

NAME	CAGE/REFERENCE	QUANTITY	REMARK
None			

Consumables, materials, and expendables

Table 4 Consumables, materials, and expendables

NAME	CAGE/REFERENCE	QUANTITY	REMARK
None			

Spares

Table 5 Spares

NAME	CAGE/REFERENCE	QUANTITY	REMARK
None			

Safety conditions

WARNING

Make sure there is no dart in the barrel.

Procedure

WARNING

Unload the phun gun when not in use.

- 1 Carefully remove the belt assembly by one of the methods below:
- 1.1 Optionally unsnap two shells and remove belt, or



ICN-07GB6-DARTS1-001-01

Figure 1. Cartridges.

- 1.2 Open the safety plate and slide entire belt over barrel to remove belt.

Requirements after job completion

Required conditions

Table 6 Required conditions

ACTION/CONDITION	DATA MODULE/TECHNICAL PUBLICATION
None	

CHAPTER 4

TEST AND INSPECTION MAINTENANCE INSTRUCTIONS

Phun Gun - Test and inspection

References

Table 1 References

CHAP NO./DOCUMENT NO.	TITLE
None	

General information

Instructions

The following procedure shall be followed during or after assembly to ensure proper assembly of the weapon.

Preliminary requirements

Required conditions

Table 2 Required conditions

ACTION/CONDITION	DATA MODULE/TECHNICAL PUBLICATION
None	

Support equipment

Table 3 Support equipment

NAME	CAGE/REFERENCE	QUANTITY	REMARK
None			

Consumables, materials, and expendables

Table 4 Consumables, materials, and expendables

NAME	CAGE/REFERENCE	QUANTITY	REMARK
None			

Spares

Table 5 Spares

NAME	CAGE/REFERENCE	QUANTITY	REMARK
None			

Safety conditions

None

Procedure

WARNING

Before starting an inspection, be sure to clear the weapon. Do not actuate the trigger before clearing the weapon. Inspect the chamber to make sure it is empty and free of obstructions. Check to see there are no obstructions in the barrel and no ammunition is in position to be chambered.

- 1 Inspect the weapon as follows:
 - 1.1 Inspect the general condition of the gun.
 - 1.2 Inspect for missing, loose, or damaged parts.
 - 1.3 Make sure all controls operate properly.
 - 1.4 Inspect the weapon in accordance with the MAC. Refer to Phun Gun - MAC [S1000DGUN-0-00-00-00-00A-916A-A].
- 2 Test the weapon in accordance with the MAC. Refer to Phun Gun - MAC [S1000DGUN-0-00-00-00-00A-916A-A].

Requirements after job completion

Required conditions

Table 6 Required conditions

ACTION/CONDITION	DATA MODULE/TECHNICAL PUBLICATION
None	

CHAPTER 5

SHIPMENT/MOVEMENT AND STORAGE MAINTENANCE INSTRUCTIONS

Phun Gun - Preparation for storage or shipment

References

Table 1 References

CHAP NO./DOCUMENT NO.	TITLE
None	

General information

Security

Security of the Phun Gun 30D is as defined in AR 190-11 Physical Security of Arms, Ammunition, and Explosives and AR 190-13 The Army Physical Security Program. Weapons will be stored in suitable containers to prevent theft, and as stated by the above security regulations. The storage area must be covered and as moisture-free as possible.

Preliminary requirements

Required conditions

Table 2 Required conditions

ACTION/CONDITION	DATA MODULE/TECHNICAL PUBLICATION
None	

Support equipment

Table 3 Support equipment

NAME	CAGE/REFERENCE	QUANTITY	REMARK
None			

Consumables, materials, and expendables

Table 4 Consumables, materials, and expendables

NAME	CAGE/REFERENCE	QUANTITY	REMARK
Wiping rags (clean, dry)	58536	AR	

Spares

Table 5 Spares

NAME	CAGE/REFERENCE	QUANTITY	REMARK
None			

Safety conditions

None

Procedure

- 1 Disassemble the Phun Gun as necessary to accomplish cleaning.
- 2 Clean all surfaces with Wiping rags (clean, dry).
- 3 Reassemble the Phun Gun.

Requirements after job completion**Required conditions****Table 6 Required conditions**

ACTION/CONDITION	DATA MODULE/TECHNICAL PUBLICATION
None	

CHAPTER 6

AMMUNITION MARKING MAINTENANCE INSTRUCTIONS

Phun Gun - Ammunition marking

References

Table 1 References

CHAP NO./DOCUMENT NO.	TITLE
FM 4-30.13	Ammunition Handbook: Tactics, Techniques, and Procedures for Munitions Handlers
MIL-STD-1168B	Ammunition Lot Numbering and Ammunition Data Card

General information

General

The ammunition for the Phun Gun is classified as small-arms ammunition and is issued in the form of a complete round. A complete round (cartridge) consists of all the components necessary to fire the weapon once, that is, projectile (dart) and shell.

Identification

A cartridge can be visually identified by the orange shell, and yellow casing and purple tip of the dart.

Care, Handling and Preservation

This ammunition is not dangerous to handle.

Ammunition boxes should be opened carefully as they are to be used as long as they are serviceable.

Ammunition boxes should not be opened until the ammunition is required for use.

Preparation for Firing

After removal from packing materials, these cartridges are ready to be used.

Preliminary requirements

Required conditions

Table 2 Required conditions

ACTION/CONDITION	DATA MODULE/TECHNICAL PUBLICATION
None	

Support equipment

Table 3 Support equipment

NAME	CAGE/REFERENCE	QUANTITY	REMARK
None			

Consumables, materials, and expendables

Table 4 Consumables, materials, and expendables

NAME	CAGE/REFERENCE	QUANTITY	REMARK
None			

Spares

Table 5 Spares

NAME	CAGE/REFERENCE	QUANTITY	REMARK
None			

Safety conditions

None

Procedure

- 1 Ammunition boxes should be painted as follows:
 - 1.1 The boxes are painted and color coded to provide an easy means of identification.
 - 1.2 The boxes shall be painted olive drab with no other special markings.
 - 1.3 Boxes may be identified with the following information in black stencil:

Lot Number	OOH11A001-001A
FSC	1395

Requirements after job completion

Required conditions

Table 6 Required conditions

ACTION/CONDITION	DATA MODULE/TECHNICAL PUBLICATION
None	

CHAPTER 7
SUPPORTING INFORMATION

Phun Gun - References

References

Table 1 References

CHAP NO./DOCUMENT NO.	TITLE
None	

1 SCOPE

This data module lists all field manuals, forms, technical manuals, and miscellaneous publications referenced in this manual.

2 PUBLICATION INDEXES

The following indexes should be consulted frequently for latest changes or revisions and for new publications relating to material covered in this technical manual:

DA PAM 25-30	Consolidated Index of Army Publications and Forms
DA PAM 750-8	The Army Maintenance Management System (TAMMS) Users Manual

3 ARMY REGULATIONS

AR 190-11	Physical Security of Arms, Ammunition and Explosives
AR 190-13	The Army Physical Security Program

4 FIELD MANUALS

FM 4-25.11	First Aid
FM 4-30.13	Ammunition Handbook: Tactics, Techniques, and Procedures for Munitions Handlers

5 FORMS

DA Form 2028	Recommended Changes to Publications and Blank Forms
DA Form 2404	Equipment Inspection and Maintenance Worksheet
SF 368	Product Quality Deficiency Report

6 OTHER PUBLICATIONS

DOD 4160.21-M-1	Defense Demilitarization Manual
MIL-STD-1168B	Ammunition Lot Numbering and Ammunition Data Card
MIL-STD-12	Abbreviations for Use on Drawings, Specifications, Standards, and Technical Documents

7 TECHNICAL MANUALS

TM 750-244-7

Procedures for Destruction of Equipment in Federal Supply
Classifications 1000, 1005, 1010, 1015, 1020, 1025, 1030, 1055,
1090, and 1095, to Prevent Enemy Use

Phun Gun - MAC introduction

References

Table 1 References

CHAP NO./DOCUMENT NO.	TITLE
None	

1 INTRODUCTION

1.1 The Army Maintenance System MAC

This introduction provides a general explanation of all maintenance and repair functions authorized at the two maintenance levels under the Two-Level Maintenance System concept. This MAC (immediately following the introduction) designates overall authority and responsibility for the performance of maintenance functions on the identified end item or component. The application of the maintenance functions to the end item or component shall be consistent with the capacities and capabilities of the designated maintenance levels, which are shown on the MAC in column (4) as:

- Field – includes two sub columns, Crew (C) and Maintainer (F).
- Sustainment – includes two sub columns, Below Depot (H) and Depot (D).

The maintenance to be performed below depot and in the field is described as follows:

- 1 Crew maintenance. The responsibility of a using organization to perform maintenance on its assigned equipment. It normally consists of inspecting, servicing, lubricating, adjusting, and replacing parts, minor assemblies, and subassemblies. The replace function for this level of maintenance is indicated by the letter "C" in the third position of the SMR code. A "C" appearing in the fourth position of the SMR code indicates complete repair is possible at the crew maintenance level.
- 2 Maintainer maintenance. Maintenance accomplished on a component, accessory, assembly, subassembly, plug-in unit, or other portion either on the system or after it is removed. The replace function for this level of maintenance is indicated by the letter "F" appearing in the third position of the SMR code. An "F" appearing in the fourth position of the SMR code indicates complete repair is possible at the field maintenance level. Items are returned to the user after maintenance is performed at this level.
- 3 Below depot sustainment. Maintenance accomplished on a component, accessory, assembly, subassembly, plug-in unit, or other portion either on the system or after it is removed. The replace function for this level of maintenance is indicated by the letter "H" appearing in the third position of the SMR code. An "H" appearing in the fourth position of the SMR code indicates complete repair is possible at the below depot sustainment maintenance level. Items are returned to the supply systems after maintenance is performed at this level.
- 4 Depot sustainment. Maintenance accomplished on a component, accessory, assembly, subassembly, plug-in unit, or other portion either on the system or after it is removed. The replace function for this level of maintenance is indicated by the letter "D" or "K" appearing in the third position of the SMR code. Depot sustainment maintenance can be performed by either depot personnel or contractor personnel. A "D" or "K" appearing in the fourth position of the SMR code indicates complete repairs possible at the depot sustainment maintenance level. Items are returned to the supply systems after maintenance is performed at this level.

The tools and test equipment requirements table (immediately following the MAC) lists the tools and test equipment (both special tools and common tool sets) required for each maintenance function as referenced from the MAC.

The remarks table (immediately following the tools and test equipment requirements) contain supplemental instructions and explanatory notes for a particular maintenance function.

1.2 Maintenance Functions

Maintenance functions are limited to and defined as follows:

- 1 Inspect. To determine the serviceability of an item by comparing its physical, mechanical, and/or electrical characteristics with established standards through examination (e.g., by sight, sound, or feel). This includes scheduled inspection and gauging and evaluation of cannon tubes.
- 2 Test. To verify serviceability by measuring the mechanical, pneumatic, hydraulic, or electrical characteristics of an item and comparing those characteristics with prescribed standards on a scheduled basis, i.e., load testing of lift devices and hydrostatic testing of pressure hoses.
- 3 Service. Operations required periodically to keep an item in proper operating condition; e.g., to clean (includes decontaminate, when required), to preserve, to drain, to paint, or to replenish fuel, lubricants, chemical fluids, or gases. This includes scheduled exercising and purging of recoil mechanisms. The following are examples of service functions:
 - 3.1 Unpack. To remove from packing box for service or when required for the performance of maintenance operations.
 - 3.2 Repack. To return item to packing box after service and other maintenance operations.
 - 3.3 Clean. To rid the item of contamination.
 - 3.4 Touch up. To spot paint scratched or blistered surfaces.
 - 3.5 Mark. To restore obliterated identification.
- 4 Adjust. To maintain or regulate, within prescribed limits, by brining into roper position, or by setting the operating characteristics to specified parameters.
- 5 Align. To adjust specified variable elements of an item to bring about optimum or desired performance.
- 6 Calibrate. To determine and cause corrections to be made or to be adjusted on instruments of test, measuring, and diagnostic equipment used in precision measurement. Consists of comparisons of two instruments, one of which is a certified standard of known accuracy, to detect and adjust any discrepancy in the accuracy of the instrument being compared.
- 7 Remove/Install. To remove and install the same item when required to perform service or other maintenance functions. Install may be the act of emplacing, seating, or fixing into position a spare, repair part, or module (component or assembly) in a manner to allow the proper functioning of an equipment or system.
- 8 Paint (ammunition only). To prepare and spray color coats of paint so that the ammunition can be identified and protected. The color indicating primary use is applied, preferably, to the entire exterior surface as the background color of the item. Other markings are to be repainted as original so as to retain proper ammunition identification.

-
- 9 Replace. To remove an unserviceable item and install a serviceable counterpart in its place "Replace" is authorized by the MAC and assigned maintenance level is shown as the third position code of the Source, Maintenance, and Recoverability (SMR) code.
 - 10 Repair. The application of maintenance services, including fault location/troubleshooting, removal/installation, disassembly/assembly procedures and maintenance actions to identify troubles and restore serviceability to an item by correcting specific damage, fault, malfunction, or failure in a part, subassembly, module (component or assembly), end item, or system.

NOTE

The following definitions are applicable to the "repair" maintenance function:

- Services. Inspect, test, service, adjust, align, calibrate, and/or replace.
 - Fault location/troubleshooting. The process of investigating and detecting the cause of equipment malfunctioning; the act of isolating a fault within a system or Unit Under Test (UUT).
 - Disassembly/assembly. The step-by-step breakdown (taking apart) of a spare/functional group coded item to the level of its least component, that is assigned an SMR code for the level of maintenance under consideration (i.e., identified as maintenance significant).
 - Actions. Welding, grinding, riveting, straightening, facing, machining, and/or resurfacing.
- 11 Overhaul. That maintenance effort (service/action) prescribed to restore an item to a completely serviceable/operational condition as required by maintenance standards in appropriate technical publications. Overhaul is normally the highest degree of maintenance performed by the Army. Overhaul does not normally return an item to like new condition.
 - 12 Rebuild. Consists of those services/actions necessary for the restoration of unserviceable equipment to a like new condition in accordance with original manufacturing standards. Rebuild is the highest degree of material maintenance applied to Army equipment. The rebuild operation includes the act of returning to zero those age measurements (e.g., hours/miles) considered in classifying Army equipment/components.

1.3 Explanation Of Entries In The MAC

Group Number. Entry lists Functional Group Code (FGC) numbers, the purpose of which is to identify maintenance significant components, assemblies, subassemblies, and modules with the Next Higher Assembly (NHA).

Component/Assembly. Entry contains the item names of components, assemblies, subassemblies, and modules for which maintenance is authorized.

Maintenance Function. Entry lists the functions to be performed on the item listed in column (2). (For a detailed explanation of these functions refer to "Maintenance Functions" outlined above).

Maintenance Level. Entry specifies each level of maintenance authorized to perform each function, by indicating work time required (expressed as man-hours in whole hours or decimals) in the appropriate sub column. This work time figure represents the active time required to perform that maintenance function at the indicated level of maintenance. If the number or complexity of the tasks within the listed maintenance function varies at different maintenance levels, appropriate work time figures are to be shown for each level. The work time figure represents the average time required to

restore an item (assembly, subassembly, component, module, end item, or system) to a serviceable condition under typical field operating conditions. This time includes preparation time (including any necessary disassembly/assembly time), troubleshooting/fault location time, and quality assurance time in addition to the time required to perform the specific tasks identified for the maintenance functions authorized in the MAC. The symbol designations for the various maintenance levels are as follows:

Field:

C	Crew maintenance
F	Maintainer maintenance

Sustainment:

L	Specialized Repair Activity (SRA)
H	Below depot maintenance
D	Depot maintenance

NOTE

The "L" maintenance level is not included in column (4) of the MAC. Functions to this level of maintenance are identified by work time figure in the "H" column of column (4), and an associated reference code is used in the REMARKS column (6). This code is keyed to the remarks and the SRA complete repair application is explained there.

Tools and Equipment Reference Code. Entry specifies, by code, those common tool sets (not individual tools), common Test, Measurement and Diagnostic Equipment (TMDE), and special tools, special TMDE and special support equipment required to perform the designated function. Codes are keyed to the entries in the tools and test equipment table.

Remarks Code. When applicable, this column contains a letter code, in alphabetical order, which is keyed to the remarks table entries.

1.4 Explanation Of Entries In The Tools And Test Equipment Requirements

Tool or Test Equipment Reference Code. The tool or test equipment reference code correlates with a code used in tasks and equipment reference code entry of the MAC.

Maintenance Level. The lowest level of maintenance authorized to use the tool or test equipment.

Nomenclature. Name or identification of the tool or test equipment.

National Stock Number (NSN). The NSN of the tool or test equipment.

Tool Number. The manufacturer's part number.

1.5 Explanation Of Entries In The Remarks

Remarks Code. The code recorded in the remarks code entry of the MAC.

Remarks. This entry lists information pertinent to the maintenance function being performed as indicated in the MAC.

Phun Gun - MAC

References

Table 1 References

CHAP NO./DOCUMENT NO.	TITLE
None	

Table 2 MAC for Phun Gun

(1) GROUP NUMBER	(2) COMPONENT/ASSEMBLY	(3) MAINTENANCE FUNCTION	(4) MAINTENANCE LEVEL				(5) TOOLS AND EQUIPMENT REF CODE	(6) REMARKS CODE
			FIELD		SUSTAINMENT			
			CREW	MAIN- TAINER	BELOW DEPOT	DEPOT		
			C	F	H	D		
00	Phun Gun	Inspect	0.3					
		Load	0.2					
		Arm	0.1					
		Unload	0.2					
		Clean	0.3					
		Overhaul				--	1	A
00A	Body Casing	None						
00AA	Receiver Assembly	Inspect		0.3				
00AB	Barrel Assembly	Inspect			--			
00AC	Trigger Assembly	Adjust			--	1	A	
		Replace				--	1	A
00AD	Belt Assembly	Assemble		0.3				
		Adjust		0.5		1	A	
		Inspect		0.3				
00AE	Slide Assembly	Inspect		0.1				
		Align		0.5		1	A	
		Remove		1.3		1	A	
		Repair		1.0		1	A	
		Replace		2.0		1	A	
00AF	Hammer Assembly	None						
00AG	Safety Plate	Align		--		1	A	
		Adjust		0.3		1	A	
		Replace		1.3		1	A	

(1) GROUP NUMBER	(2) COMPONENT/ASSEMBLY	(3) MAINTENANCE FUNCTION	(4) MAINTENANCE LEVEL				(5) TOOLS AND EQUIPMENT REF CODE	(6) REMARKS CODE
			FIELD		SUSTAINMENT			
			CREW	MAIN- TAINER	BELOW DEPOT	DEPOT		
			C	F	H	D		
00AH	Safety Plate Release Button	Adjust					1	A

Table 3 Tools and Test Equipment for Phun Gun

TOOLS OF TEST EQUIPMENT REF CODE	MAINTENANCE LEVEL	NOMENCLATURE	NATIONAL STOCK NUMBER	TOOL NUMBER
1	F	Tool kit, Small arms	5180-01-462-4254	SC5180-95-B71

Table 4 Remarks for Phun Gun

REMARKS CODE	REMARKS
A	Only required tool needed from kit: SCREWDRIVER, CROSS TIP #1 PHILLIPS 3/8 SQ DR.

Phun Gun - Components of End Item (COEI) list

References

Table 1 References

CHAP NO./DOCUMENT NO.	TITLE
None	

1 INTRODUCTION

1.1 SCOPE

The COEI for the Phun Gun helps inventory items for safe and efficient operation of the equipment.

1.2 GENERAL

Components of End Item (COEI). This list is for information purposes only and is not authority to requisition replacements. These items are part of the Phun Gun. As part of the end item, these items must be with the end item whenever it is issued or transferred between property accounts. Items of COEI are removed and separately packaged for transportation or shipment only when necessary. Illustrations are furnished to help you find and identify the items.

1.3 Explanation Of Columns In The COEI List

- 1 "Item Number" column . Gives you the reference number of the item listed.
- 2 "National Stock Number (NSN)" column. Identifies the stock number of the item to be used for requisitioning purposes.
- 3 "Description, Part Number/(CAGEC)" column. Identifies the Federal item name (in all capital letters) followed by a minimum description when needed. The stowage location of COEI is also included in this column. The last line below the description is the part number and the Commercial and Government Entity Code (CAGEC) (in parentheses).
- 4 "Usable On Code" column. Indicates a code if the item needed is not the same for different models of equipment.
- 5 "U/I" column. Unit of Issue (U/I) indicates the physical measurement or count of the item as issued per the National Stock Number shown in column (2).
- 6 "Qty Rqr" column. Indicates the quantity required.



ICN-07GB6-COEI1-001-01

Figure 1. Components of End Item.

Table 2 Components of End Item List

Item Number	National Stock Number (NSN)	Description, Part Number/ (CAGEC)	Usable On Code	U/I	Qty Rqr
1	0000-00-000-0000	DART BELT DB-30SHELL/(77777)		EA	1

Phun Gun - Basic Issue Items (BII) list

References

Table 1 References

CHAP NO./DOCUMENT NO.	TITLE
None	

1 INTRODUCTION

1.1 Scope

The BII for the Phun Gun, helps inventory items for safe and efficient operation of the equipment.

1.2 General

Basic Issue Items (BII). These essential items are required to place the Phun Gun in operation, operate it, and to do emergency repairs. Although shipped separately packaged, BII shall be with the Phun Gun during operation and when it is transferred between property accounts. Listing these items is your authority to request/requisition them for replacement based on authorization of the end item by the TOE/MTOE. Illustrations are furnished to help you find and identify the items.

1.3 Explanation Of Columns In The BII List

- 1 "Item Number" column. Gives you the reference number of the item listed.
- 2 "National Stock Number (NSN)" column. Identifies the stock number of the item to be used for requisitioning purposes.
- 3 "Description, Part Number/(CAGEC)" column. Identifies the Federal item name (in all capital letters) followed by a minimum description when needed. The stowage location of BII is also included in this column. The last line below the description is the part number and the Commercial and Government Entity Code (CAGEC) (in parentheses).
- 4 "Usable On Code" column. When applicable, gives you a code if the item you need is not the same for different models of equipment.
- 5 "U/I" column. Unit of Issue (U/I) indicates the physical measurement or count of the item as issued per the National Stock Number shown in column (2).
- 6 "Qty Rqr" column. Indicates the quantity required.



ICN-07GB6-BII01-001-01

Figure 1. Basic Issue Items.

Table 2 Basic Issue Items List

Item Number	National Stock Number (NSN)	Description, Part Number/ (CAGEC)	Usable On Code	U/I	Qty Rqr
1	0000-00-000-0000	CASE, PHUN GUN		EA	1
2		PHUN-CASE1/(77777) CASE, DART DC-00-0001/(77777)		EA	1

Phun Gun - Additional Authorization List (AAL)

References

Table 1 References

CHAP NO./DOCUMENT NO.	TITLE
None	

1 INTRODUCTION

1.1 Scope

This lists additional items you are authorized for the support of the Phun Gun.

1.2 General

This list identifies items that do not have to accompany the Phun Gun and that do not have to be turned in with it. These items are all authorized to you by CTA, MTOE, TDA, or JTA.

1.3 Explanation Of Columns In The AAL

- 1 "National Stock Number (NSN)" column. Identifies the stock number of the item to be used for requisitioning purposes.
- 2 "Description, Part Number/(CAGEC)" column. Identifies the Federal item name (in all capital letters) followed by a minimum description when needed. The stowage location of BII is also included in this column. The last line below the description is the part number and the Commercial and Government Entity Code (CAGEC) (in parentheses).
- 3 "Usable On Code" column. When applicable, gives you a code if the item you need is not the same for different models of equipment.
- 4 "U/I" column. Unit of Issue (U/I) indicates the physical measurement or count of the item as issued per the National Stock Number shown in column (1).
- 5 "Qty Recm" column. Indicates the quantity recommended.

Table 2 Additional Authorization List

National Stock Number (NSN)	Description, Part Number/(CAGEC)	Usable On Code	U/I	Qty Recm
0000-00-000-0000	Mount PHUN-MNT-01/(77777)		EA	1
0000-00-000-0000	Night Vision Sight DC-00-0001/(77777)	XXX	EA	1
0000-00-000-0000	Tripod PG-3POD-01/(77777)		EA	1

Phun Gun - Expendable and durable items list

References

Table 1 References

CHAP NO./DOCUMENT NO.	TITLE
None	

1 INTRODUCTION

1.1 Scope

This lists expendable and durable items that you will need to operate and maintain the of the Phun Gun. This list is for information only and is not authority to requisition the listed items. These items are authorized to you by CTA 50-970, Expendable/Durable Items (Except Medical, Class V Repair Parts, and Heraldic Items), CTA 50-909, Field and Garrison Furnishings and Equipment or CTA 8-100, Army Medical Department Expendable/Durable Items.

1.2 Explanation Of Columns In The Expendable/Durable Items List

- 1 "Item No." column. This number is assigned to the entry in the list and is referenced in the narrative instructions to identify the item.
- 2 "Level" column. This entry identifies the lowest level of maintenance that requires the listed item (C = Crew (Operator), F = Maintainer, H = Below Depot, D = Depot).
- 3 "National Stock Number (NSN)" column. Identifies the stock number of the item to be used for requisitioning purposes.
- 4 "Item name, Description, Part Number/(CAGE)" column. This column provides the other information you need to identify the item. The last line below the description is the part number and the Commercial and Government Entity Code (CAGE) (in parentheses).
- 5 "U/I" column. Unit of Issue (U/I) code shows the physical measurement or count of the item, such as gallon, dozen, gross, etc.

Table 2 Expendable/Durable Items List

Item No.	Level	National Stock Number (NSN)	Item Name, Description, Part Number/ (CAGEC)	U/I
1	C	1005-00-494-6602	Brush, Cleaning	EA
2	C	7920-00-205-1711	Rag, Wiping: Cotton, 50 LB bundle 58536A-A-351	EA

Phun Gun - Reporting errors and recommending improvements

References

Table 1 References

CHAP NO./DOCUMENT NO.	TITLE
None	

RECOMMENDED CHANGES TO PUBLICATIONS AND BLANK FORMS	USE PART II (REVERSE) FOR PARTS LISTS AND SUPPLY CATALOGS/SUPPLY MANUALS (SUC/SUM)	DATE
FOR USE OF THIS FORM, SEE AR 25-30; PROPONENT AGENCY HAS NOT APPROVED THIS FORM.		
TO: (FORWARD TO PROPONENT OF PUBLICATION OR FORM) (INCLUDE ZIP CODE)	FROM: (ACTIVITY AND LOCATION) (INCLUDE ZIP CODE)	

PART I - ALL PUBLICATIONS (EXCEPT PARTS LISTS AND SUM/SUC) AND BLANK FORMS

PUBLICATION/FORM NUMBER	DATE	TITLE

ITEM	PAGE	PARA-	LINE	FIGUR E NO.	TABL E	RECOMMENDED CHANGES AND REASON

TYPED NAME, GRADE OR TITLE	TELEPHONE EXCHANGE/ DSN, PLUS EXTENSION	SIGNATURE
----------------------------	--	-----------

TO: <i>(Forward direct to addresses listed in publication)</i>	FROM: <i>(Activity and location) (Include Zip Code)</i>	DATE
---	--	-------------

PART II - PARTS LISTS AND SUPPLY CATALOG/SUPPLY MANUALS

PUBLICATION NUMBER				DATE			TITLE	
PAGE NO.	COL M NO.	LINE NO.	NATIONAL STOCK NUMBER	REFERENCE NO.	FIGURE NO.	ITEM NO.	TOTAL NO. OF MAJOR ITEMS SUPPORTED	RECOMMENDED ACTION

PART III - REMARKS*(Any general remarks or recommendations, or suggestions for improvement of publications and blank forms. Additional blank sheets may be used if more space is needed.)*

TYPED NAME, GRADE OR TITLE	TELEPHONE EXCHANGE/DSN, PLUS EXTENSION	SIGNATURE

DA FORM 2028, MAR 2011

NOT APPROVED FOR OFFICIAL USE

BTAS COE v1.00

Phun Gun - Authentication page

References

Table 1 References

CHAP NO./DOCUMENT NO.	TITLE
None	

By Order of the Secretary of the Army:

PETER J. SCHOOMAKER
General, United States Army
 Chief of Staff

Official:

 JOYCE E. MORROW
Administrative Assistant to the
Secretary of the Army
 0635401

DISTRIBUTION: To be distributed in accordance with the initial distribution number (IDN) 381111, requirements for TM 9-2320-303-10.

ICN-1L6T4-AUTHENT-001-01

Figure 1. Authentication Block.

